

DETAIL "A" (S=32:1)

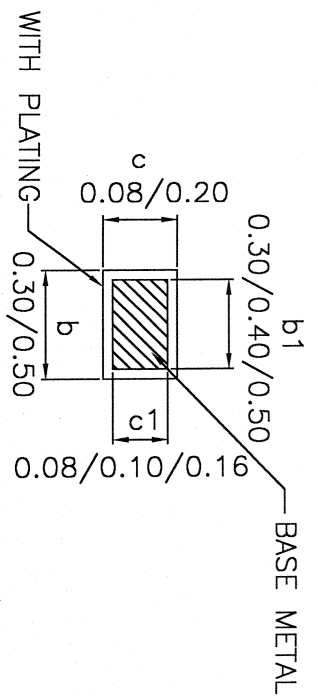

SECTION "B"-"B"

NOTES:

1. DIMENSION D1 & E1 DOES NOT INCLUDE MOLD PROTRUSION.
2. COPLANARITY OF ALL LEADS SHALL BE (BEFORE TEST) 0.1 MAX. FROM THE SEATING PLANE. UNLESS OTHERWISE SPECIFIED.
3. GENERAL PHYSICAL OUTLINE SPEC IS REFER TO TMC'S FINAL VISUAL INSPECTION SPEC UNLESS OTHERWISE SPECIFIED.

REV.	DESCRIPTION OF REVISION	SIGNATURE/DATE
3		
2	MODIFY DIM	JANE LOU 50/12/24
1	MODIFY DIM	JANE LOU 88/09/22

昌揚科技股份有限公司 <i>Taiwan Microtopag Corporation</i>		TITLE SOT 25 PACKAGE OUTLINE DWG.	
DWG. NO.	EOL-A0050000-001	FILE	EOLA6-001
DESIGNER	JANE LOU	SCALE	16 : 1
CHECKER		SHEET NO.	1 OF 1
APPROVED		UNIT	MM
THIRD ANGLE PROJECTION 		ALL DIMENSIONS IN MILLIMETERS.	