

P-Ch 60V Fast Switching MOSFETs

Electrical Characteristics ($T_J = 25^\circ\text{C}$ unless otherwise specified):

Static Characteristics						
Symbol	Parameter	Test Conditions	Value			Units
			Min.	Typ.	Max.	
V_{DSS}	Drain to Source Breakdown Voltage	$V_{GS}=0V, I_D=-250\mu A$	-60	--	--	V
I_{DSS}	Drain to Source Leakage Current	$V_{DS} = -60V, V_{GS}= 0V$	--	--	1	μA
$I_{GSS(F)}$	Gate to Source Forward Leakage	$V_{GS} = -20V$	--	--	100	nA
$I_{GSS(R)}$	Gate to Source Reverse Leakage	$V_{GS} = +20V$	--	--	-100	nA
$V_{GS(TH)}$	Gate Threshold Voltage	$V_{DS}=V_{GS}, I_D=-250\mu A$	-1.3	-1.8	-2.3	V
$R_{DS(ON)1}$	Drain-to-Source Resistance	On- $V_{GS}=-10V, I_D=-20A$	--	12	16	$m\Omega$
$R_{DS(ON)2}$	Drain-to-Source Resistance	On- $V_{GS}=-4.5V, I_D=-10A$	--	16	20	$m\Omega$

Dynamic Characteristics						
Symbol	Parameter	Test Conditions	Value			Units
			Min.	Typ.	Max.	
C_{iss}	Input Capacitance	$V_{GS}=0V$ $V_{DS}=-30V$ $f=1.0MHz$	--	2630	--	pF
C_{oss}	Output Capacitance		--	484	--	
C_{rss}	Reverse Transfer Capacitance		--	9.4	--	
R_g	Gate resistance	$V_{GS}=0V, V_{DS}$ Open	--	12.5	--	Ω

Resistive Switching Characteristics						
Symbol	Parameter	Test Conditions	Value			Units
			Min.	Typ.	Max.	
$t_{d(ON)}$	Turn-on Delay Time	$I_D=-10A, R_L=3.0\Omega$ $V_{DS}= -30V$ $V_{GS}= -10V$ $R_G= 3\Omega$	--	20	--	ns
t_r	Rise Time		--	25	--	
$t_{d(OFF)}$	Turn-Off Delay Time		--	60	--	
Note:	Fall Time		--	30	--	
Q_g	Total Gate Charge	$V_{GS}=-10V$ $V_{DS}=-30V$ $I_D=-10A$	--	38	--	nC
Q_{gs}	Gate Source Charge		--	6.9	--	
Q_{gd}	Gate Drain Charge		--	4.98	--	

Source-Drain Diode Characteristics						
Symbol	Parameter	Test Conditions	Value			Units
			Min.	Typ.	Max.	
I_S	Diode Forward Current	$T_C=25^\circ C$	--	--	-60	A
V_{SD}	Diode Forward Voltage	$I_S=-5.0A, V_{GS}=0V$	--	--	-1.2	V
t_{rr}	Reverse Recovery time	$I_S=-10A, V_{DD}=-30V$ $dI/dt=100A/\mu s$	--	50	--	ns
Q_{rr}	Reverse Recovery Charge		--	80	--	nC

Characteristics Curve:

Typ. output characteristics
 $-I_D = f(-V_{DS})$

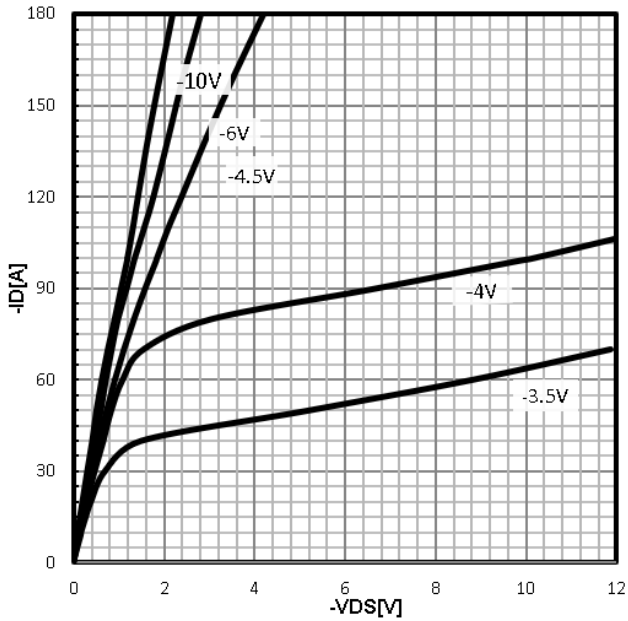

Typ. drain-source on resistance
 $R_{DS(on)} = f(-I_D)$

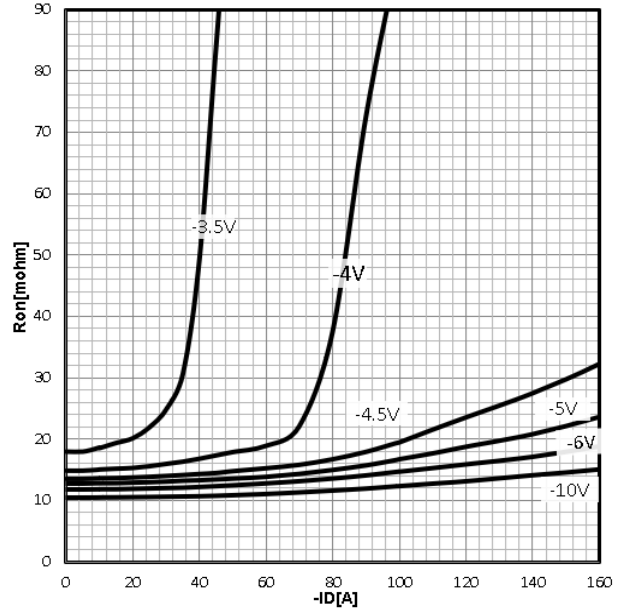

Typ. transfer characteristics
 $-I_D = f(-V_{GS})$

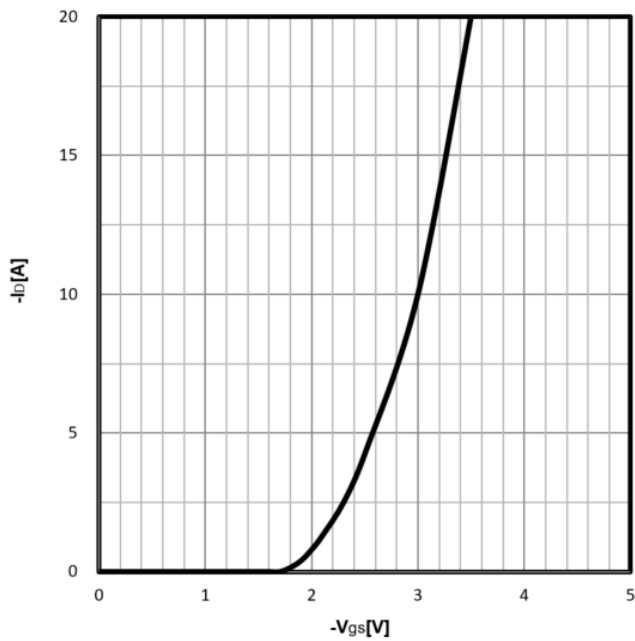

Drain-source on-state resistance
 $R_{DS(on)} = f(T_j); I_D = -20A; V_{GS} = -10V$

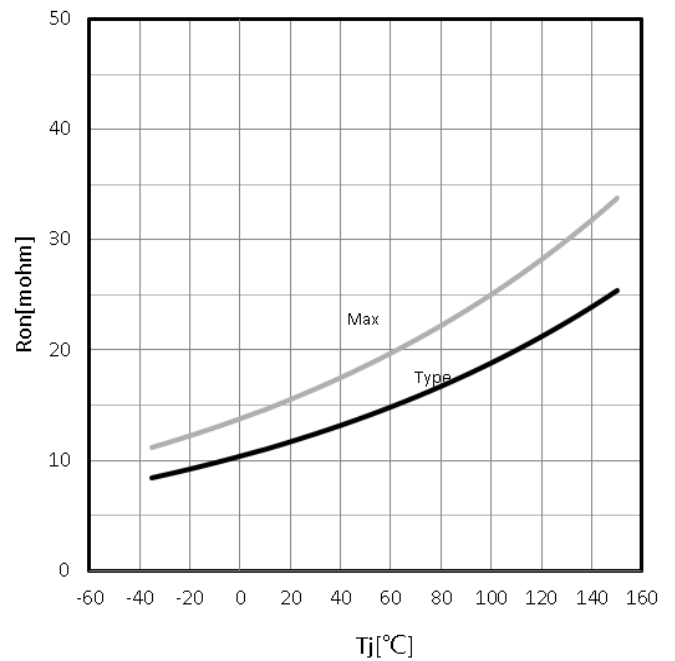

Gate Threshold Voltage
 $-V_{TH}=f(T_j); I_D=-250\mu A$

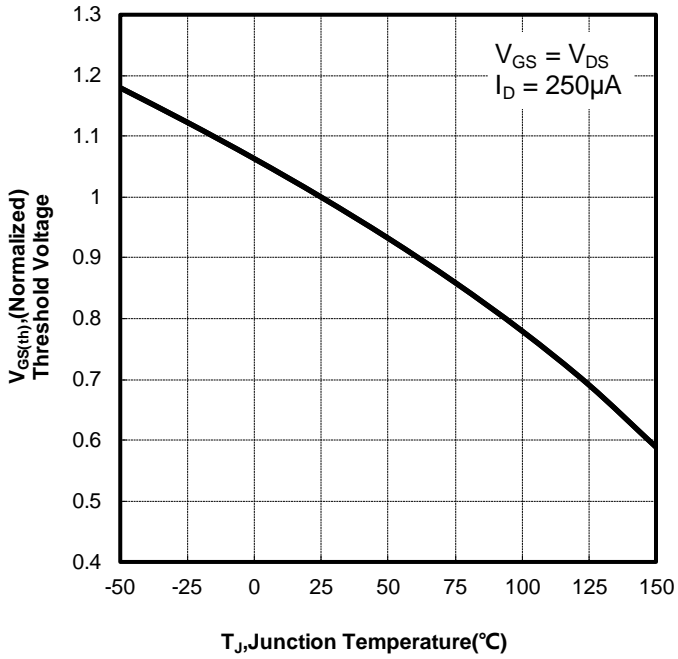

Drain-source breakdown voltage
 $-V_{BR(DSS)}=f(T_j); I_D=-250\mu A$

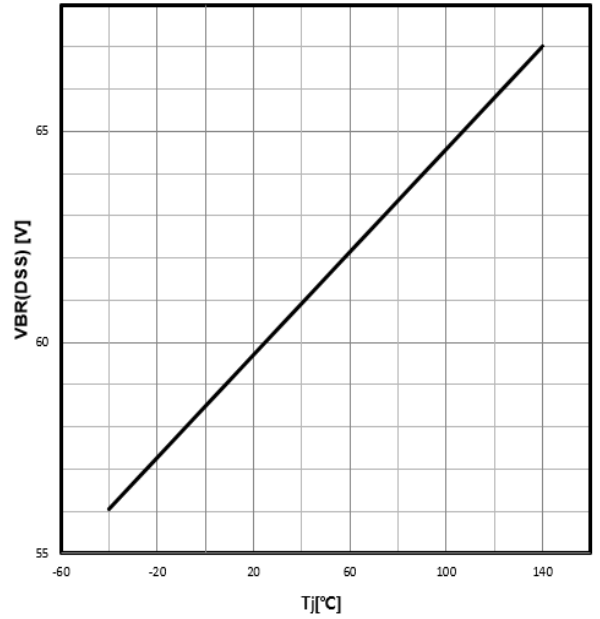

Typ. gate charge
 $V_{GS}=f(Q_{gate}); I_D=-10A$

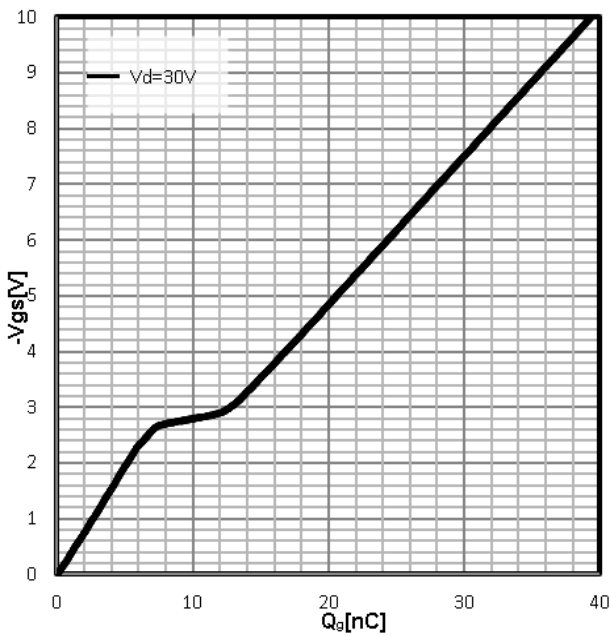

Typ. Capacitances
 $C=f(-V_{DS}); V_{GS}=0V; f=1MHz$

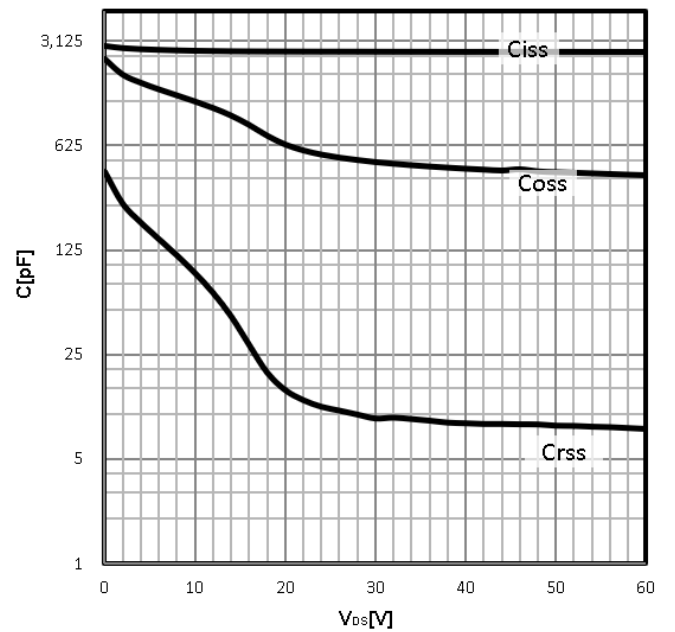

Power Dissipation
 $P_{tot}=f(T_C)$

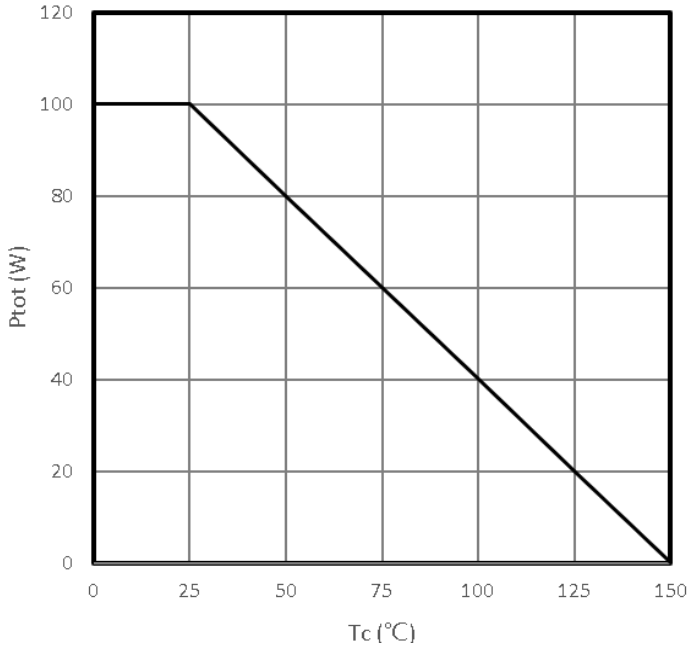

Maximum Drain Current
 $-I_D=f(T_C)$

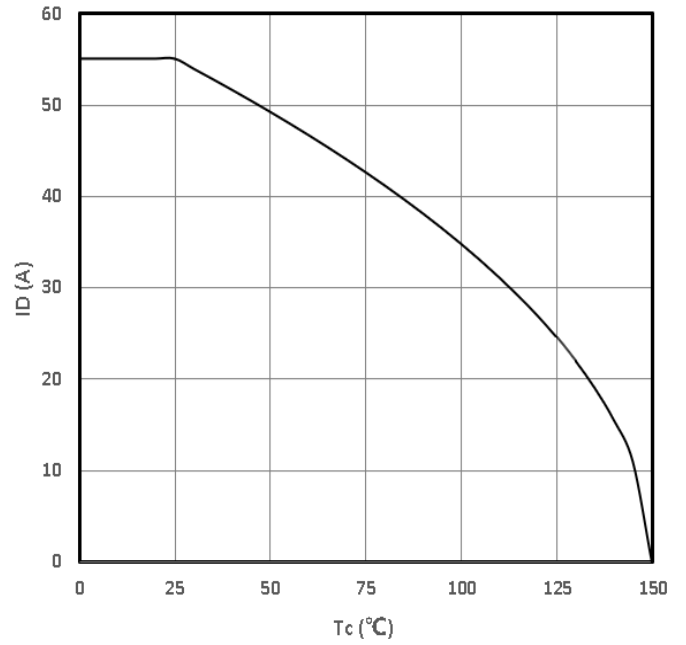

Safe operating area
 $-I_D=f(-V_{DS})$

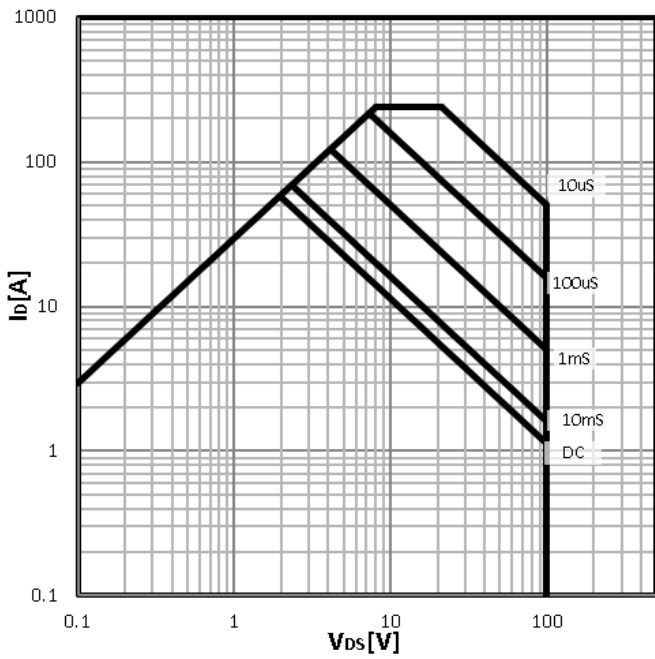

Body Diode Forward Voltage Variation
 $-I_F=f(-V_{DS})$

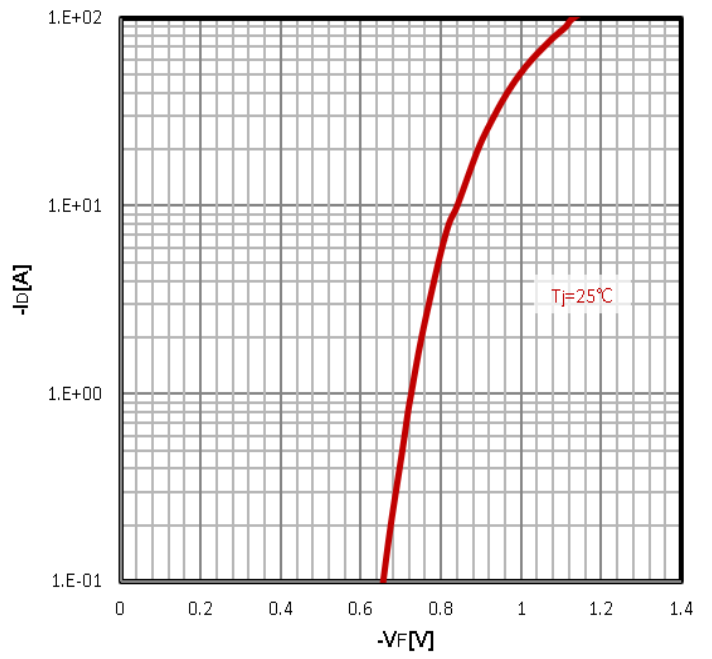

Max. transient thermal impedance

$$Z_{thJC} = f(t_p)$$

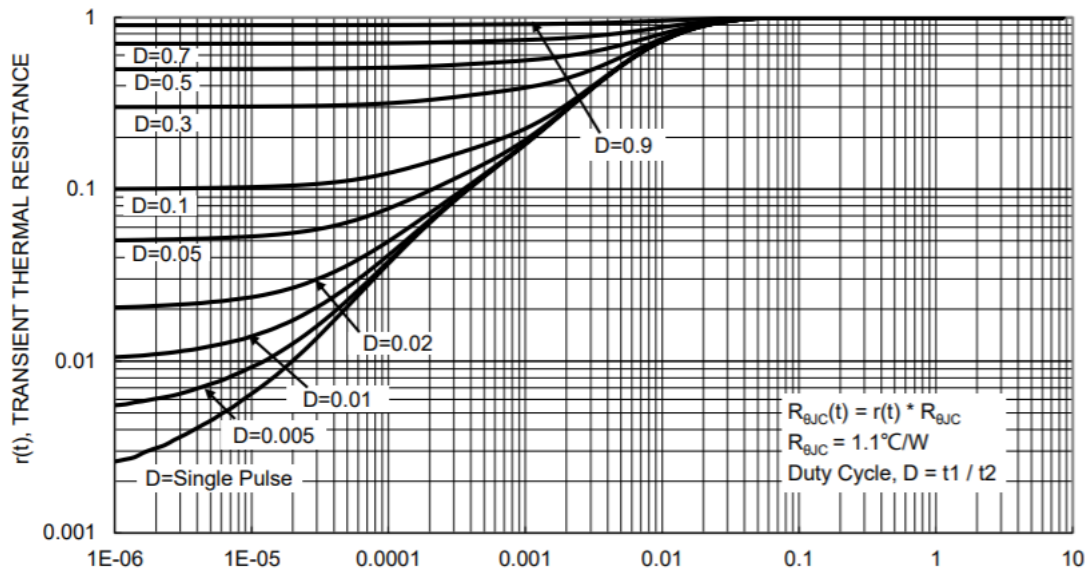

Test Circuit and Waveform

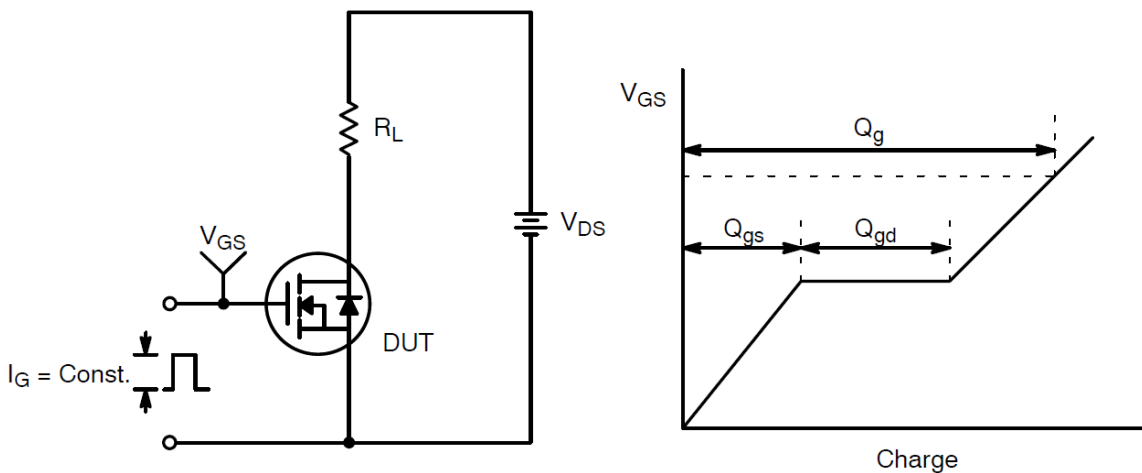

Gate Charge Test Circuit & Waveform

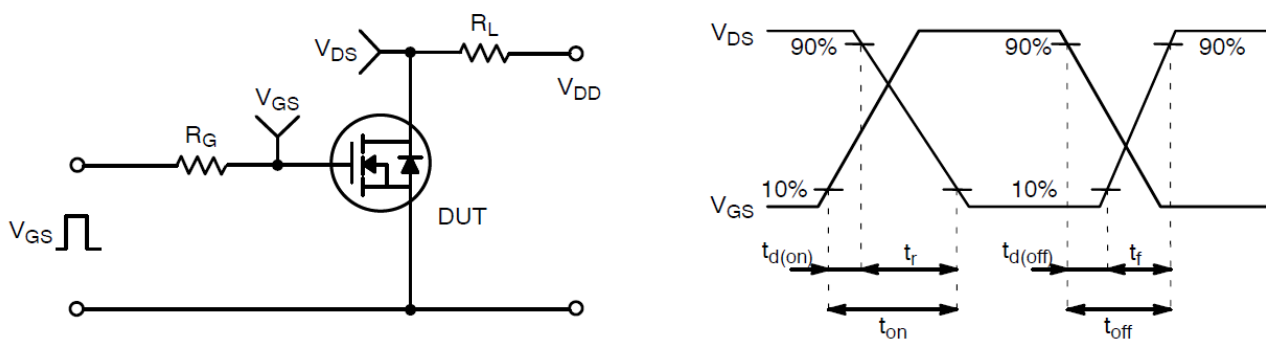

Resistive Switching Test Circuit & Waveforms

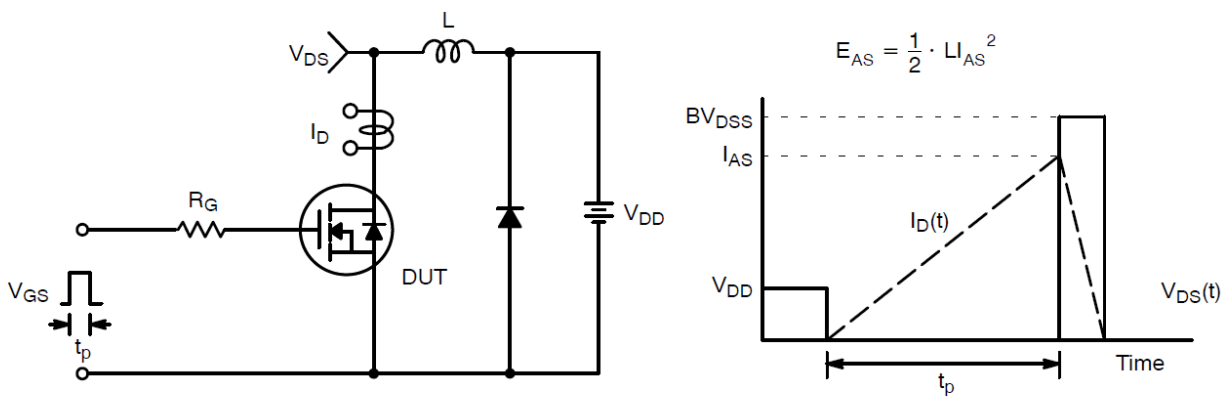

Unclamped Inductive Switching Test Circuit & Waveforms

Package Information: TO-252-3L

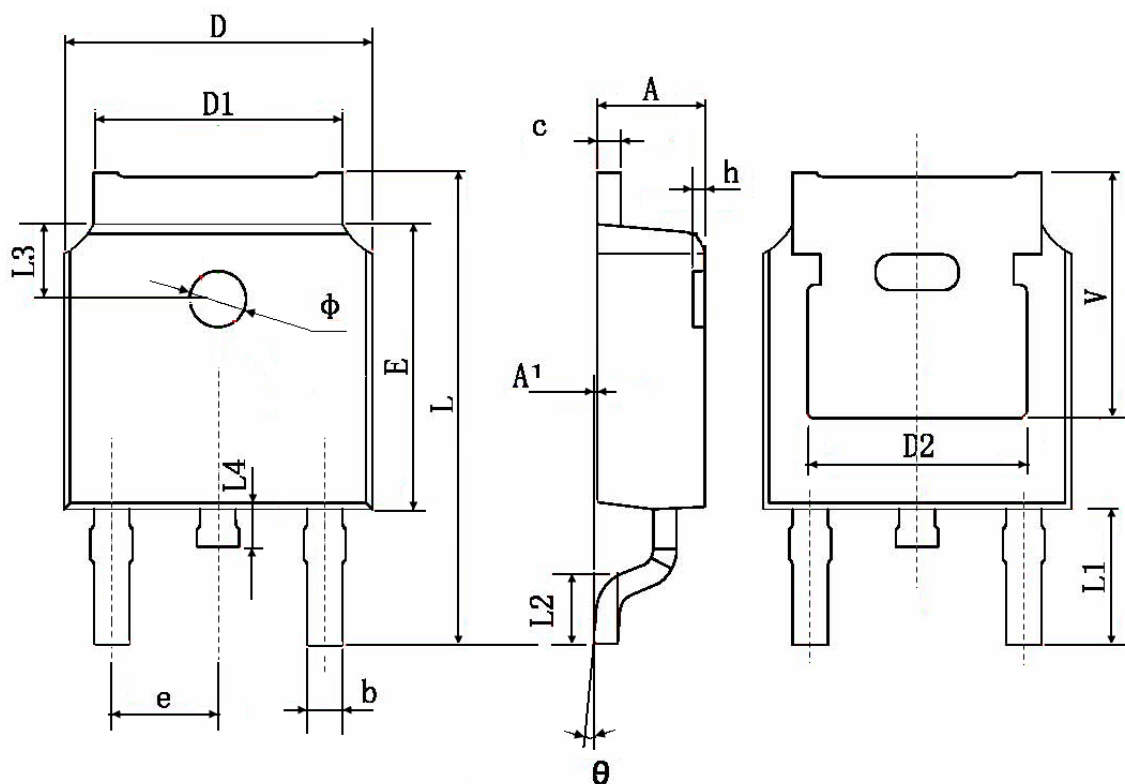

Symbol	Dimensions In Millimeters		Dimensions In Inches	
	Min.	Max.	Min.	Max.
A	2.200	2.400	0.087	0.094
A1	0.000	0.127	0.000	0.005
b	0.660	0.860	0.026	0.034
c	0.460	0.580	0.018	0.023
D	6.500	6.700	0.256	0.264
D1	5.100	5.460	0.201	0.215
D2	4.830 TYP.		0.190 TYP.	
E	6.000	6.200	0.236	0.244
e	2.186	2.386	0.086	0.094
L	9.800	10.400	0.386	0.409
L1	2.900 TYP.		0.114 TYP.	
L2	1.400	1.700	0.055	0.067
L3	1.600 TYP.		0.063 TYP.	
L4	0.600	1.000	0.024	0.039
Φ	1.100	1.300	0.043	0.051
θ	0°	8°	0°	8°
h	0.000	0.300	0.000	0.012
V	5.350 TYP.		0.211 TYP.	