

TM80P04D

P-Channel Enhancement Mosfet

Electrical Characteristics (T_J = 25°C, unless otherwise noted)

Parameter	Symbol	Test Conditions	Min.	Typ.	Max.	Unit	
Static Characteristics							
Drain-Source Breakdown Voltage	V _{(BR)DSS}	V _{GS} = 0V, I _D = -250μA	-40	-	-	V	
Gate-body Leakage current	I _{GSS}	V _{DS} = 0V, V _{GS} = ±20V	-	-	±100	nA	
Zero Gate Voltage Drain Current	I _{DSS}	V _{DS} = -40V, V _{GS} = 0V	T _J =25°C	-	-	-1	pA
			T _J =100°C	-	-	-100	
Gate-Threshold Voltage	V _{GS(th)}	V _{DS} = V _{GS} , I _D = -250μA	-1.0	-1.6	-2.5	V	
Drain-Source on-Resistance ⁴	R _{DS(on)}	V _{GS} = -10V, I _D = -20A	-	6.4	8.1	mΩ	
		V _{GS} = -4.5V, I _D = -15A	-	8.2	11		
Forward Transconductance ⁴	g _{fs}	V _{DS} = -10V, I _D = -20A	-	104	-	S	
Dynamic Characteristics⁵							
Input Capacitance	C _{iss}	V _{DS} = -20V, V _{GS} = 0V, f = 1MHz	-	5295	-	pF	
Output Capacitance	C _{oss}		-	430	-		
Reverse Transfer Capacitance	C _{rss}		-	385	-		
Gate Resistance	R _g	f = 1MHz	-	4.3	-	Q	
Switching Characteristics⁵							
Total Gate Charge	Q _g	V _{GS} = -10V, V _{DS} = -20V, I _D = -20A	-	110	-	nC	
Gate-Source Charge	Q _{gs}		-	12.5	-		
Gate-Drain Charge	Q _{gd}		-	23	-		
Turn-on Delay Time	t _{d(on)}	V _{GS} = -10V, V _{DD} = -20V, R _C = 3Ω, I _D = -20A	-	16.8	-	ns	
Rise Time	t _r		-	10	-		
Turn-off Delay Time	t _{d(off)}		-	65	-		
Fall Time	t _f		-	17	-		
Body Diode Reverse Recovery Time	t _{rr}	I _F = -20A, dI/dt = 100A/μs	-	42	-	ns	
Body Diode Reverse Recovery Charge	Q _{rr}		-	29	-	nC	
Drain-Source Body Diode Characteristics							
Diode Forward Voltage ⁴	V _{SD}	I _S = -20A, V _{GS} = 0V	-	-	-1.2	V	
Continuous Source Current	I _S	T _C =25°C	-	-	-80	A	

Notes:

1. Repetitive rating, pulse width limited by junction temperature T_{J(MAX)}=150°C.
2. The EAS data shows Max. rating. The test condition is V_{DD}= -30V, V_{GS}= -10V, L= 0.1mH, I_{AS}= -45A.
3. The data tested by surface mounted on a 1 inch2 FR-4 board with 2OZ copper, The value in any given application depends on the user's specific board design.
4. The data tested by pulsed, pulse width ≤ 300us, duty cycle ≤ 2%.
5. This value is guaranteed by design hence it is not included in the production test.

Typical Characteristics

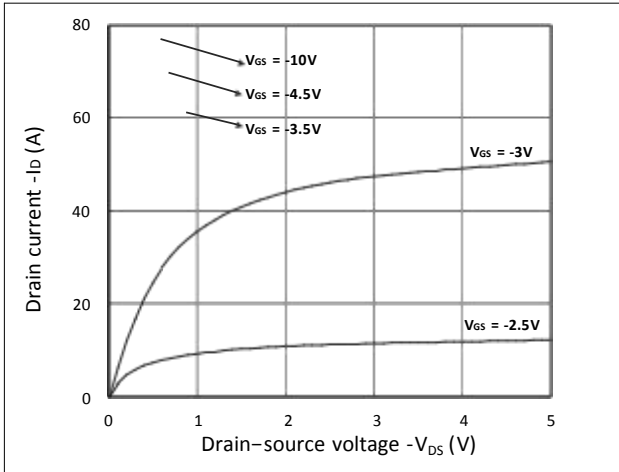

Figure 1. Output Characteristics

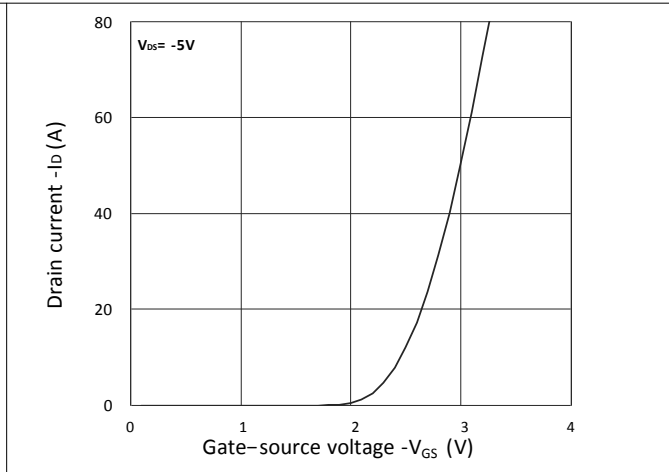

Figure 2. Transfer Characteristics

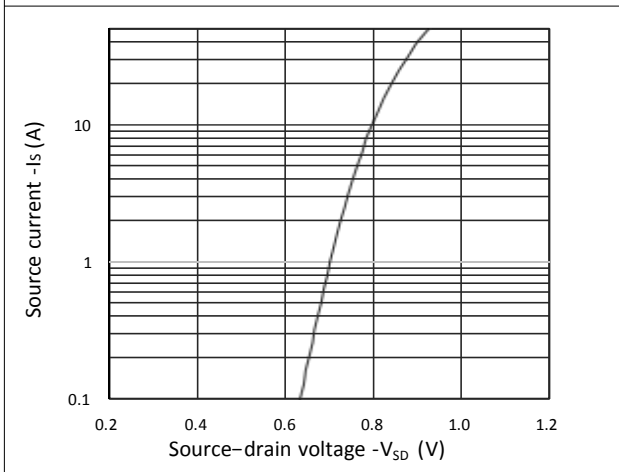

Figure 3. Forward Characteristics of Reverse

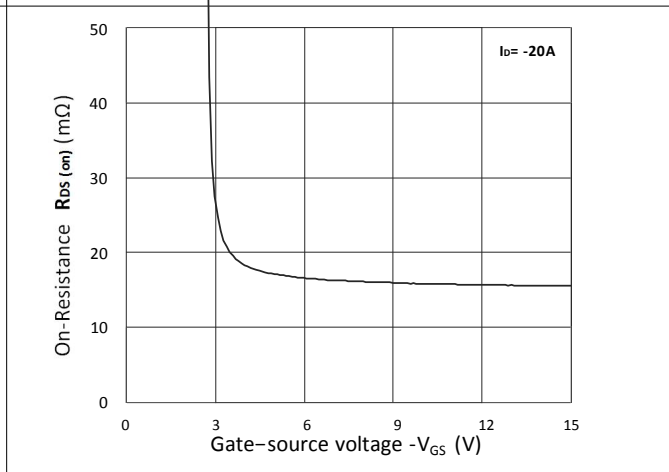

Figure 4. $R_{DS(on)}$ vs V_{GS}

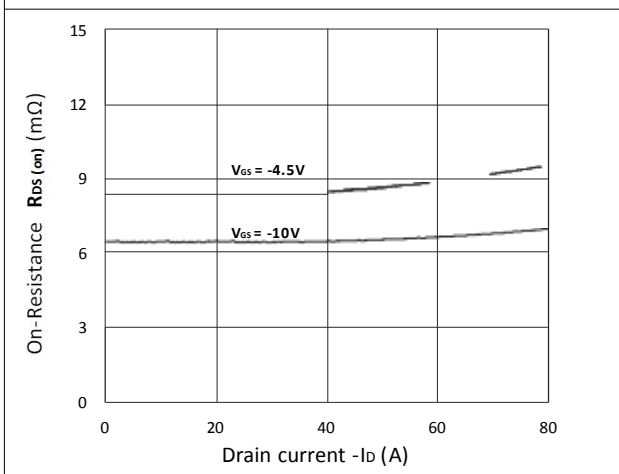

Figure 5. $R_{DS(on)}$ vs I_D

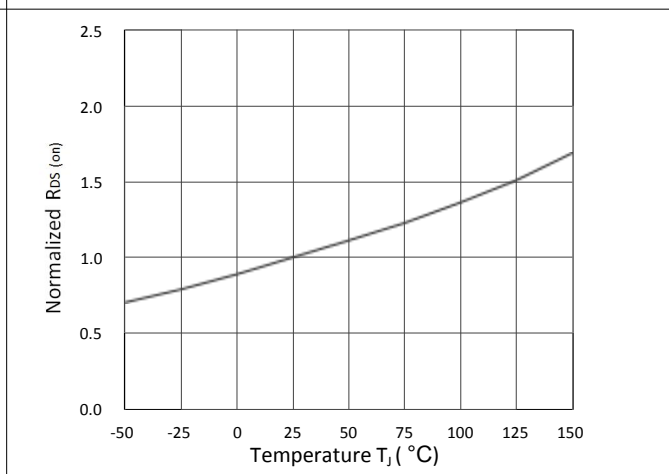

Figure 6. Normalized $R_{DS(on)}$ vs Temperature

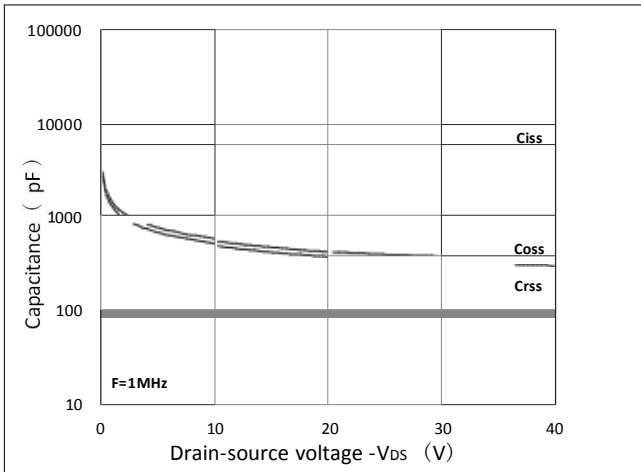

Figure 7. Capacitance Characteristics

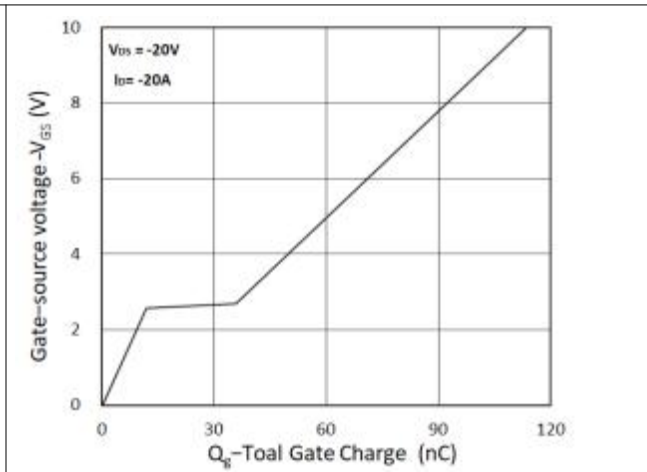

Figure 8. Gate Charge Characteristics

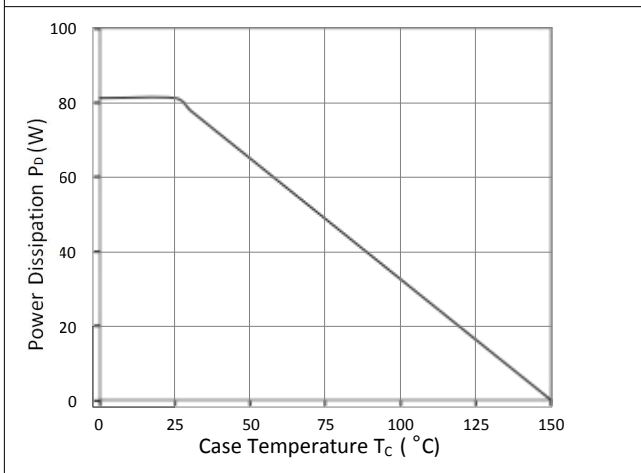

Figure 9. Power Dissipation

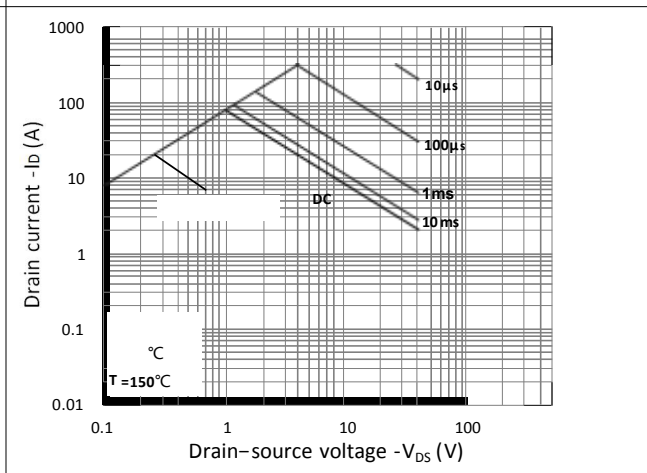

Figure 10. Safe Operating Area

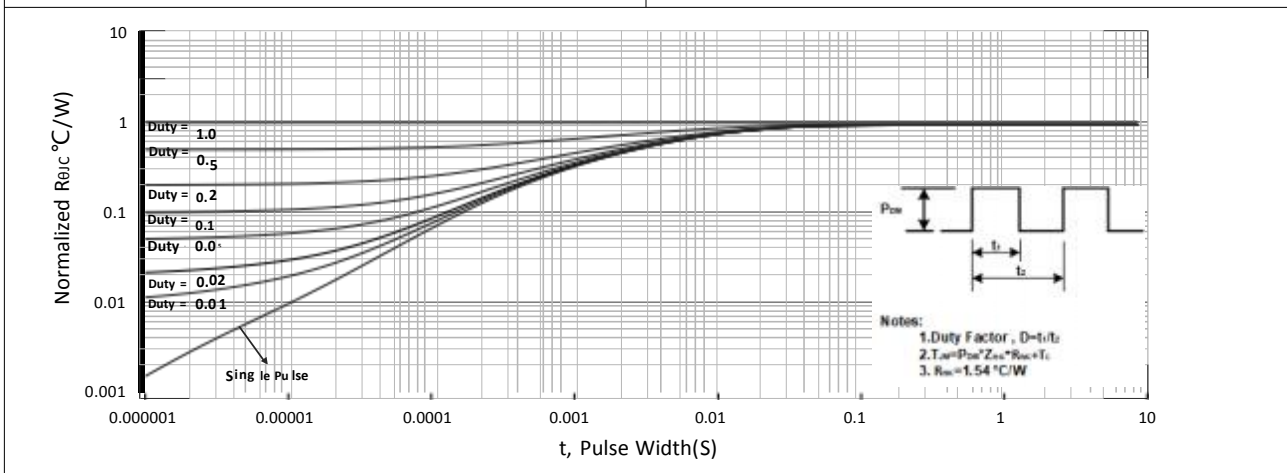
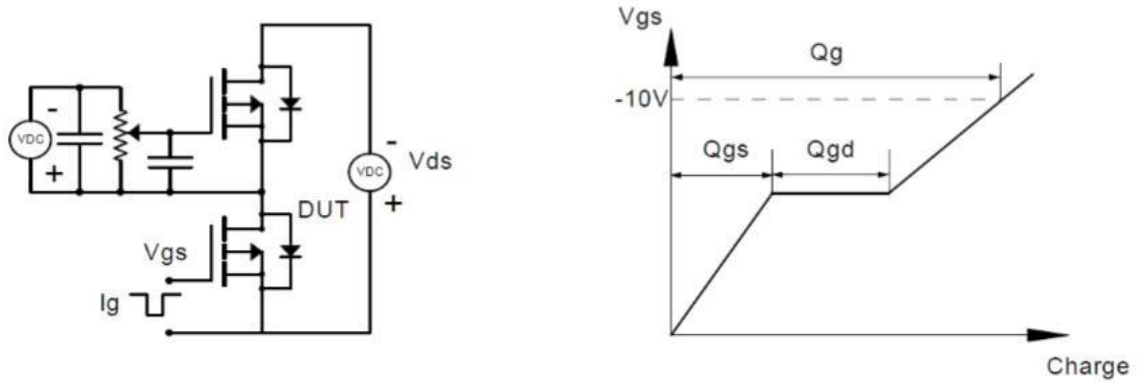

Figure 11. Normalized Maximum Transient Thermal Impedance

Test Circuit

Gate Charge Test Circuit & Waveform



Resistive Switching Test Circuit & Waveforms

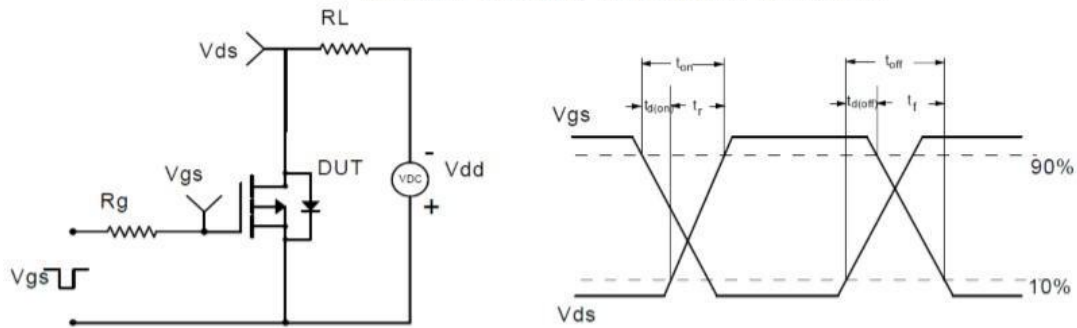

Unclamped Inductive Switching (UIS) Test Circuit & Waveforms

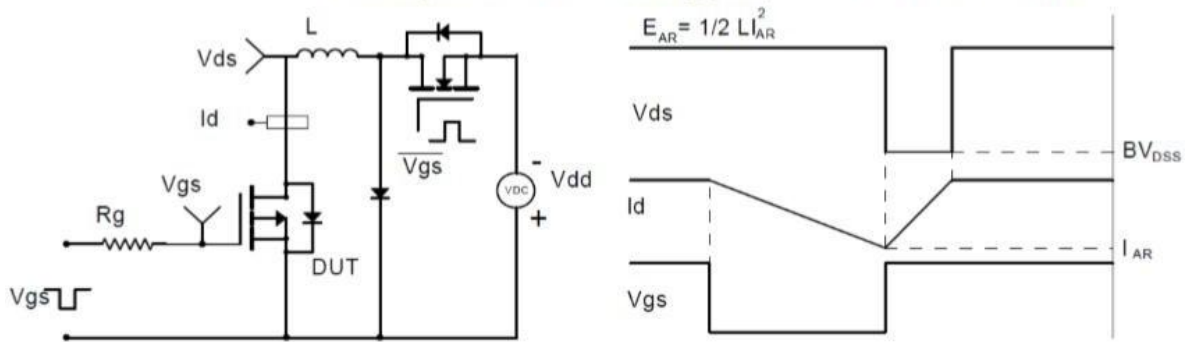

Diode Recovery Test Circuit & Waveforms

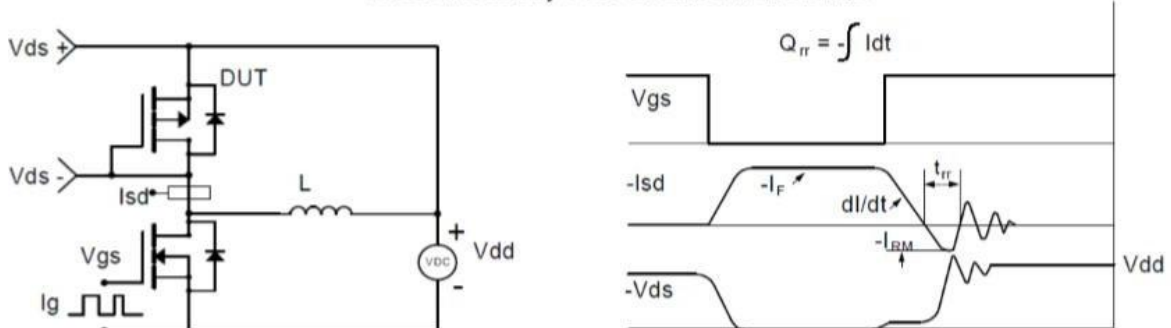

Package Information: TO-252-3L

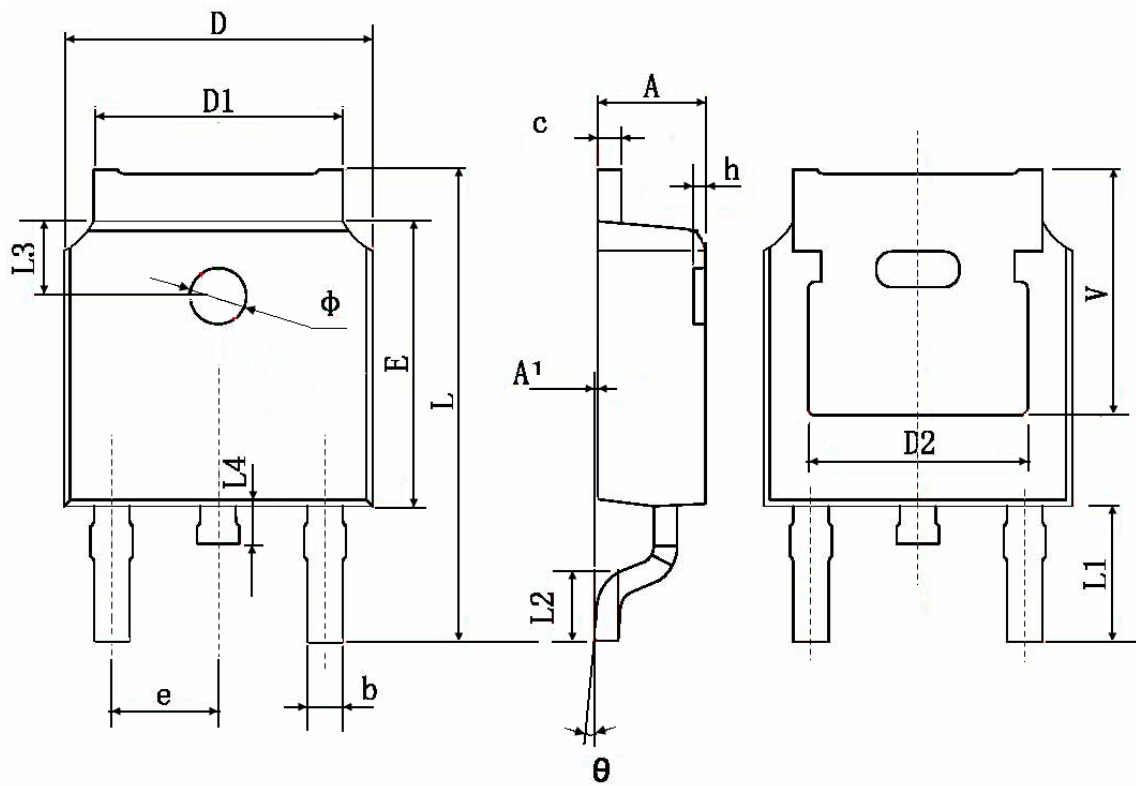

Symbol	Dimensions In Millimeters		Dimensions In Inches	
	Min.	Max.	Min.	Max.
A	2.200	2.400	0.087	0.094
A1	0.000	0.127	0.000	0.005
b	0.660	0.860	0.026	0.034
c	0.460	0.580	0.018	0.023
D	6.500	6.700	0.256	0.264
D1	5.100	5.460	0.201	0.215
D2	4.830 TYP.		0.190 TYP.	
E	6.000	6.200	0.236	0.244
e	2.186	2.386	0.086	0.094
L	9.800	10.400	0.386	0.409
L1	2.900 TYP.		0.114 TYP.	
L2	1.400	1.700	0.055	0.067
L3	1.600 TYP.		0.063 TYP.	
L4	0.600	1.000	0.024	0.039
phi	1.100	1.300	0.043	0.051
theta	0°	8°	0°	8°
h	0.000	0.300	0.000	0.012
V	5.350 TYP.		0.211 TYP.	