



**Electrical Characteristics (T<sub>J</sub>=25°C unless otherwise noted)**

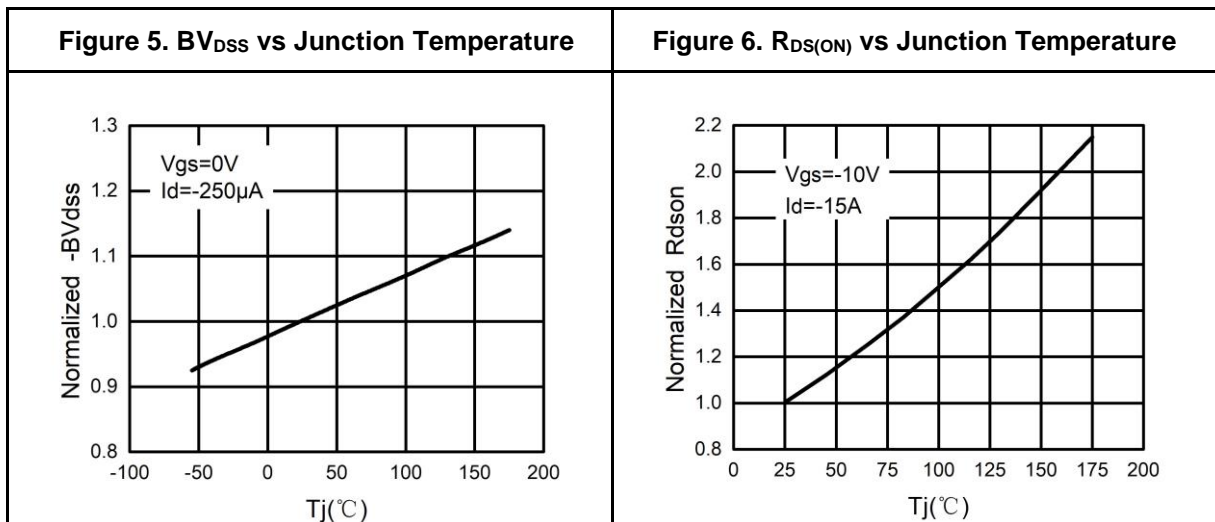
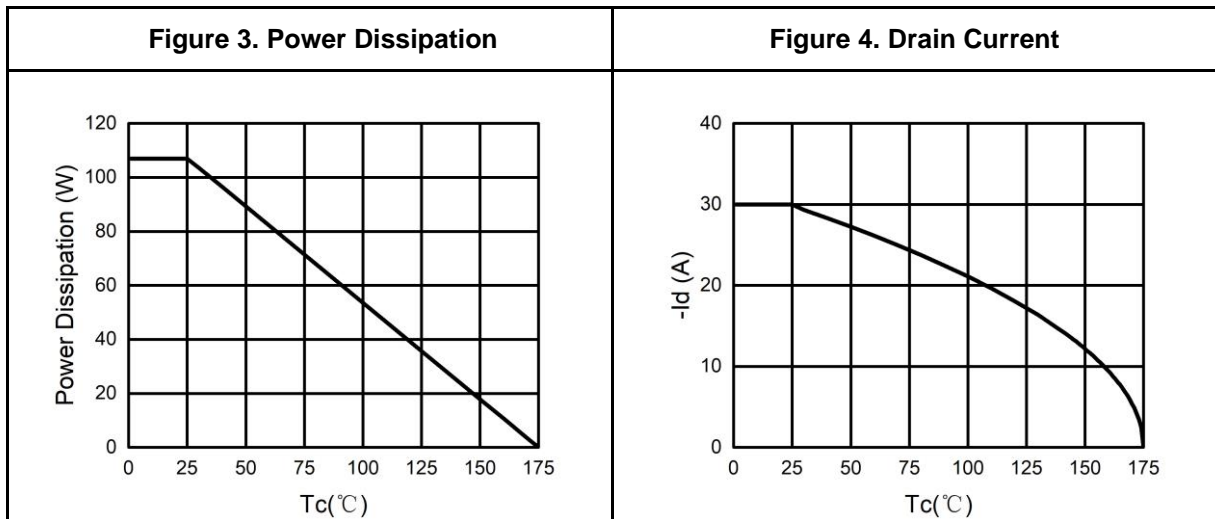
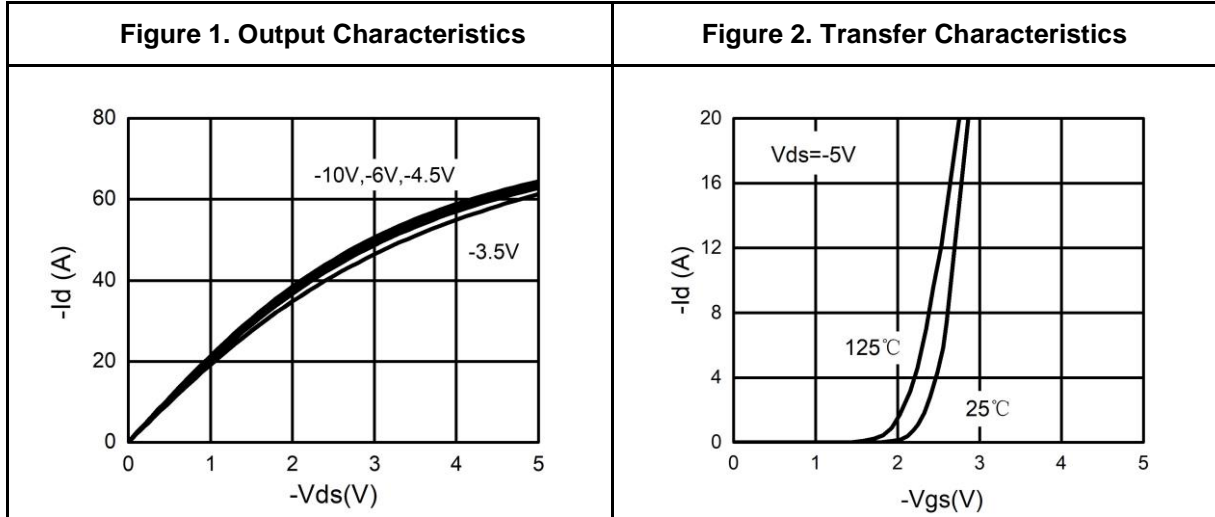
Symbol	Parameter	Conditions	Min	Typ	Max	Unit
<b>On/Off States</b>						
BV <sub>DSS</sub>	Drain-Source Breakdown Voltage	V <sub>GS</sub> =0V I <sub>D</sub> =-250μA	-100	-127		V
I <sub>DSS</sub>	Zero Gate Voltage Drain Current	V <sub>DS</sub> =-100V, V <sub>GS</sub> =0V			-1	μA
I <sub>GSS</sub>	Gate-Body Leakage Current	V <sub>GS</sub> =±20V, V <sub>DS</sub> =0V			±100	nA
V <sub>GS(th)</sub>	Gate Threshold Voltage	V <sub>DS</sub> =V <sub>GS</sub> , I <sub>D</sub> =-250μA	-1	-1.8	-2.5	V
g <sub>FS</sub>	Forward Transconductance	V <sub>DS</sub> =-5V, I <sub>D</sub> =-15A		50		S
R <sub>DS(ON)</sub>	Drain-Source On-State Resistance	V <sub>GS</sub> =-10V, I <sub>D</sub> =-15A		52	57	mΩ
		V <sub>GS</sub> =-4.5V, I <sub>D</sub> =-10A		58	66	mΩ
<b>Dynamic Characteristics</b>						
C <sub>ISS</sub>	Input Capacitance	V <sub>DS</sub> =-25V, V <sub>GS</sub> =0V, f=1.0MHz		4056		pF
C <sub>OSS</sub>	Output Capacitance			195		pF
C <sub>rSS</sub>	Reverse Transfer Capacitance			70		pF
<b>Switching Parameters</b>						
t <sub>d(on)</sub>	Turn-on Delay Time	V <sub>GS</sub> =-10V, V <sub>DS</sub> =-50V, R <sub>L</sub> =3.3Ω, R <sub>GEN</sub> =9.1Ω		13		nS
t <sub>r</sub>	Turn-on Rise Time			64		nS
t <sub>d(off)</sub>	Turn-Off Delay Time			36		nS
t <sub>f</sub>	Turn-Off Fall Time			52		nS
Q <sub>g</sub>	Total Gate Charge	V <sub>GS</sub> =-10V, V <sub>DS</sub> =-50V, I <sub>D</sub> =-10A		147		nC
Q <sub>gs</sub>	Gate-Source Charge			17		nC
Q <sub>gd</sub>	Gate-Drain Charge			31		nC
<b>Source-Drain Diode Characteristics</b>						
I <sub>SD</sub>	Source-Drain Current (Body Diode)				-25	A
V <sub>SD</sub>	Forward on Voltage (Note 3)	V <sub>GS</sub> =0V, I <sub>S</sub> =-15A			-1.2	V
t <sub>rr</sub>	Reverse Recovery Time	I <sub>F</sub> =-15A, di/dt=100A/μs		72		ns
Q <sub>rr</sub>	Reverse Recovery Charge	I <sub>F</sub> =-15A, di/dt=100A/μs		120		nC

Notes 1.Repetitive Rating: Pulse width limited by maximum junction temperature.

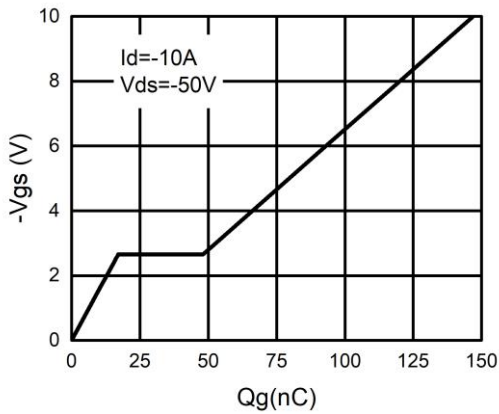
Notes 2.E<sub>AS</sub> condition: T<sub>J</sub>=25°C, V<sub>DD</sub>=50V, V<sub>G</sub>=-10V, R<sub>G</sub>=25Ω, L=0.5mH.

Notes 3.Repetitive Rating: Pulse width limited by maximum junction temperature.

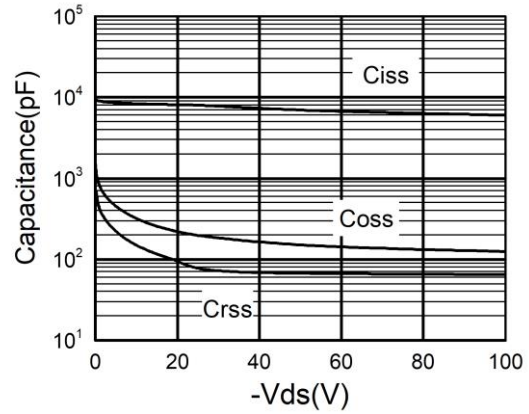
**Typical Electrical And Thermal Characteristics (Curves)**



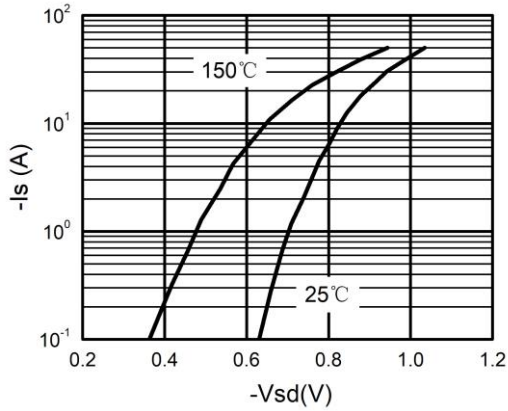
**Figure 7. Gate Charge Waveforms**



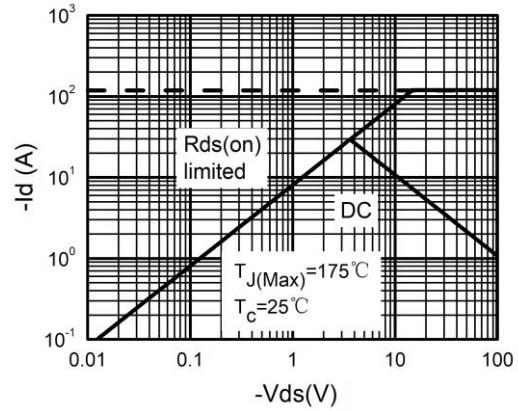
**Figure 8. Capacitance**



**Figure 9. Body-Diode Characteristics**

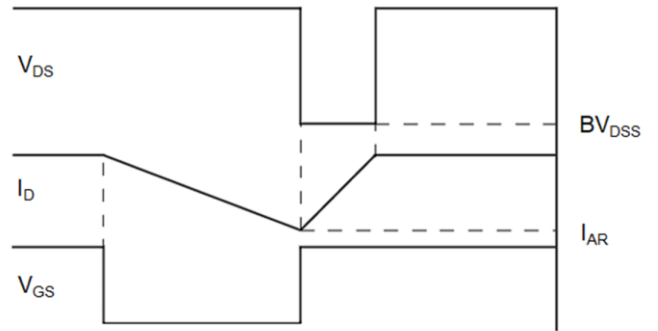
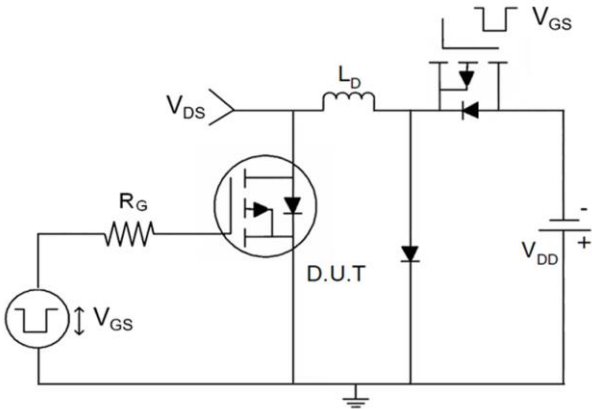


**Figure 10. Maximum Safe Operating Area**

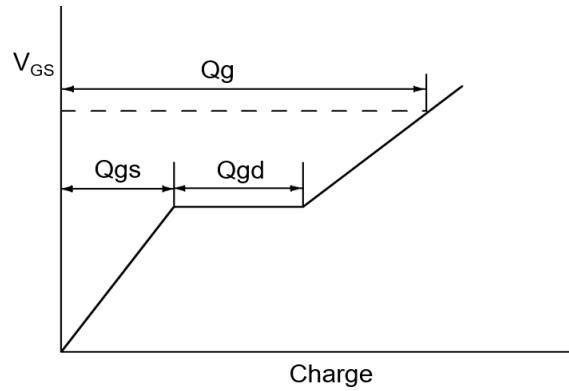
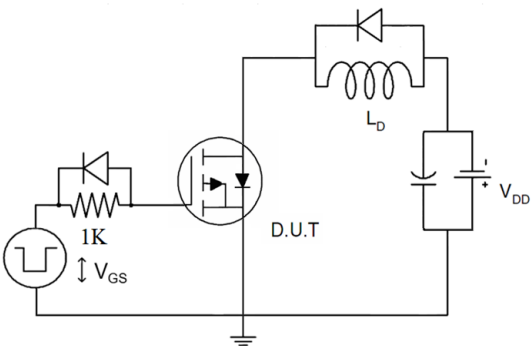


**Test Circuit**

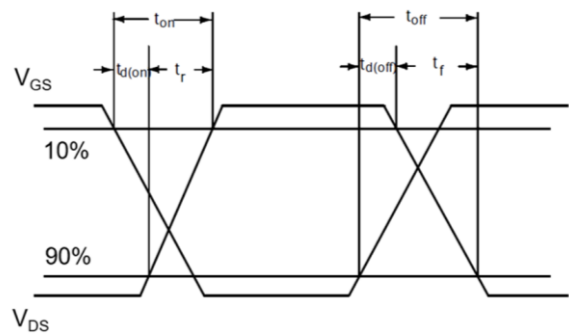
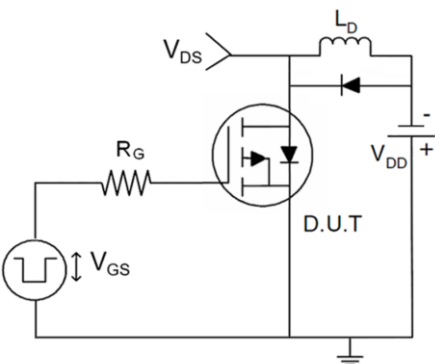
**1)  $E_{AS}$  Test Circuits**



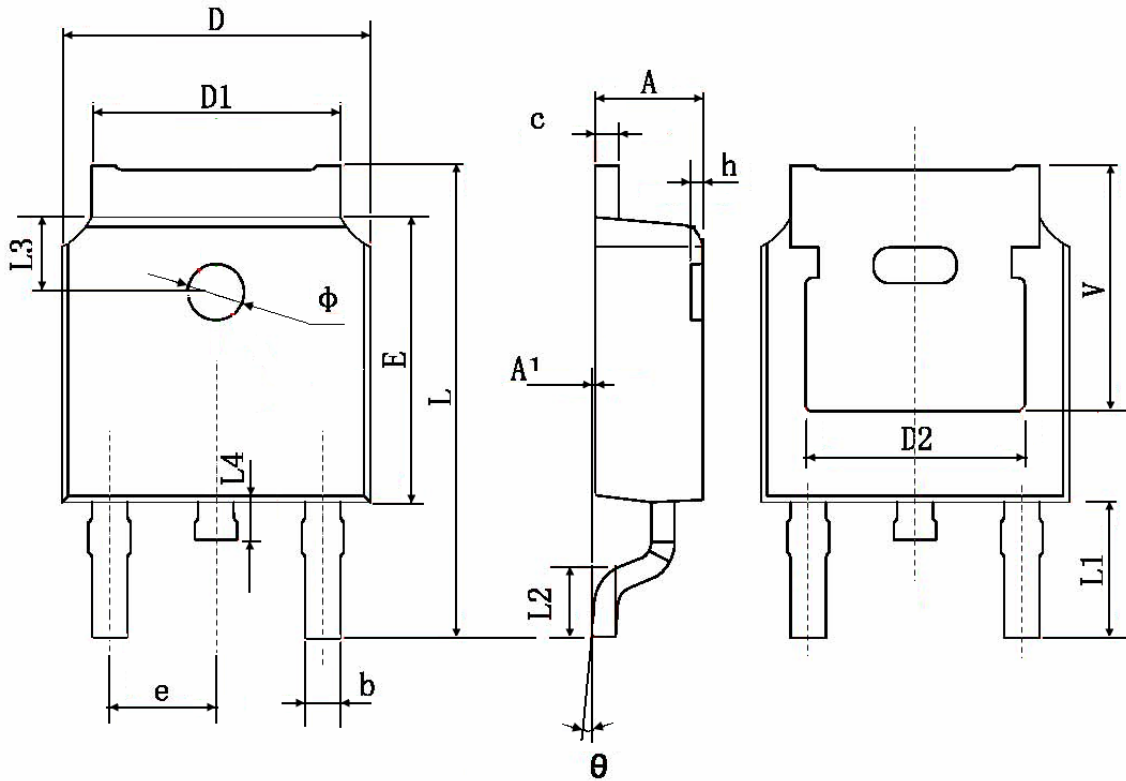
**2) Gate Charge Test Circuit**



**3) Switch Time Test Circuit**



## Package Information:TO-252-3L



Symbol	Dimensions In Millimeters		Dimensions In Inches	
	Min.	Max.	Min.	Max.
A	2.200	2.400	0.087	0.094
A1	0.000	0.127	0.000	0.005
b	0.660	0.860	0.026	0.034
c	0.460	0.580	0.018	0.023
D	6.500	6.700	0.256	0.264
D1	5.100	5.460	0.201	0.215
D2	4.830 TYP.		0.190 TYP.	
E	6.000	6.200	0.236	0.244
e	2.186	2.386	0.086	0.094
L	9.800	10.400	0.386	0.409
L1	2.900 TYP.		0.114 TYP.	
L2	1.400	1.700	0.055	0.067
L3	1.600 TYP.		0.063 TYP.	
L4	0.600	1.000	0.024	0.039
φ	1.100	1.300	0.043	0.051
θ	0°	8°	0°	8°
h	0.000	0.300	0.000	0.012
V	5.350 TYP.		0.211 TYP.	