



**Electrical Characteristics (T =25°C unless otherwise noted)**

Symbol	Parameter	Condition	Min	Typ	Max	Unit
<b>Static Electrical Characteristics @ T<sub>J</sub> = 25°C (unless otherwise stated)</b>						
V <sub>(BR)DSS</sub>	Drain-Source Breakdown Voltage	V <sub>GS</sub> =0V I <sub>D</sub> =-250μA	-60	--	--	V
I <sub>DSS</sub>	Zero Gate Voltage Drain Current(T <sub>A</sub> =25°C)	V <sub>DS</sub> =-60V, V <sub>GS</sub> =0V	--	--	-1	μA
	Zero Gate Voltage Drain Current(T <sub>A</sub> =125°C)	V <sub>DS</sub> =-60V, V <sub>GS</sub> =0V	--	--	-100	uA
I <sub>GSS</sub>	Gate-Body Leakage Current	V <sub>GS</sub> =±20V, V <sub>DS</sub> =0V	--	--	±100	nA
V <sub>GS(TH)</sub>	Gate Threshold Voltage	V <sub>DS</sub> =V <sub>GS</sub> , I <sub>D</sub> =-250μA	-1.0	-1.6	-2.5	V
R <sub>DS(ON)</sub>	Drain-Source On-State Resistance②	V <sub>GS</sub> =-10V, I <sub>D</sub> =-2A	--	160	180	mΩ
R <sub>DS(ON)</sub>	Drain-Source On-State Resistance②	V <sub>GS</sub> =-4.5V, I <sub>D</sub> =-1A	--	180	250	mΩ
<b>Dynamic Electrical Characteristics @ T<sub>J</sub> = 25°C (unless otherwise stated)</b>						
C <sub>iss</sub>	Input Capacitance	V <sub>DS</sub> =-30V, V <sub>GS</sub> =0V, f=1MHz	--	310	--	pF
C <sub>oss</sub>	Output Capacitance		--	22	--	pF
C <sub>rss</sub>	Reverse Transfer Capacitance		--	15	--	pF
Q <sub>g</sub>	Total Gate Charge	V <sub>DS</sub> =-30V I <sub>D</sub> =-2A, V <sub>GS</sub> =-10V	--	5.4	--	nC
Q <sub>gs</sub>	Gate Source Charge		--	1.1	--	nC
Q <sub>gd</sub>	Gate Drain Charge		--	1.6	--	nC
<b>Switching Characteristics</b>						
t <sub>d(on)</sub>	Turn on Delay Time	V <sub>DD</sub> =-30V, I <sub>D</sub> =-2A, R <sub>G</sub> =3.3Ω, V <sub>GS</sub> =-10V	--	41	--	ns
t <sub>r</sub>	Turn on Rise Time		--	22	--	ns
t <sub>d(off)</sub>	Turn Off Delay Time		-	25	--	ns
t <sub>f</sub>	Turn Off Fall Time		--	32	--	ns
<b>Source Drain Diode Characteristics</b>						
I <sub>SD</sub>	Source drain current(Body Diode)	T <sub>A</sub> =25°C	--	--	-2.0	A
V <sub>SD</sub>	Forward on voltage②	T <sub>J</sub> =25°C, I <sub>SD</sub> =-2A, V <sub>GS</sub> =0V	--	-0.84	-1.2	V

Notes: ① Pulse width limited by maximum allowable junction temperature

②Pulse test ; Pulse width≤300μs, duty cycle≤2%.

Typical Characteristics

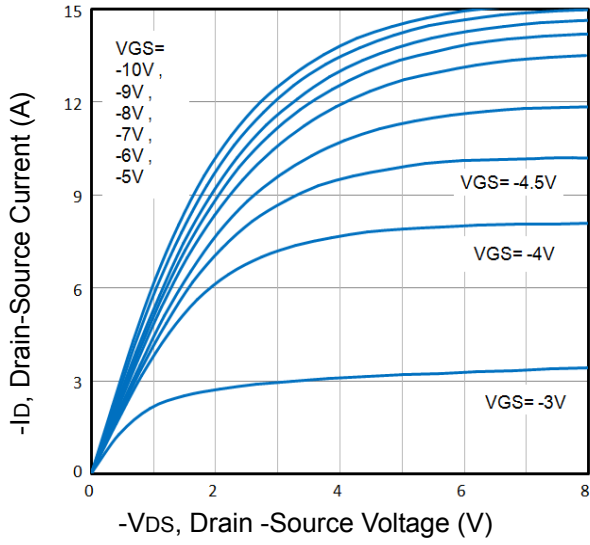

Fig1. Typical Output Characteristics

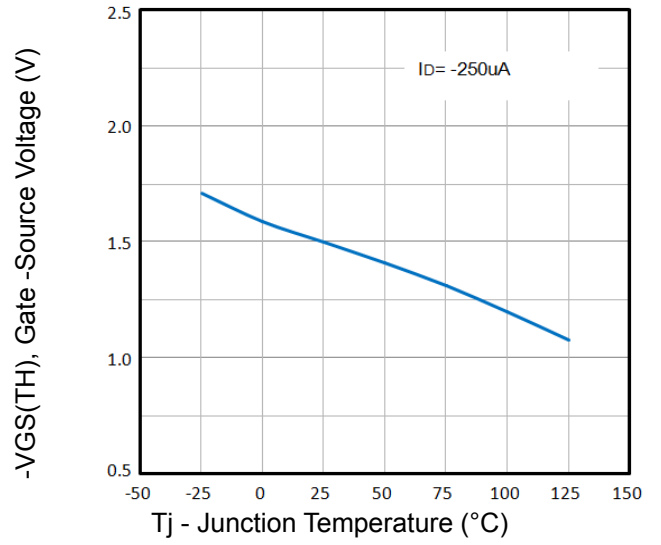

Fig2. Normalized Threshold Voltage Vs. Temperature

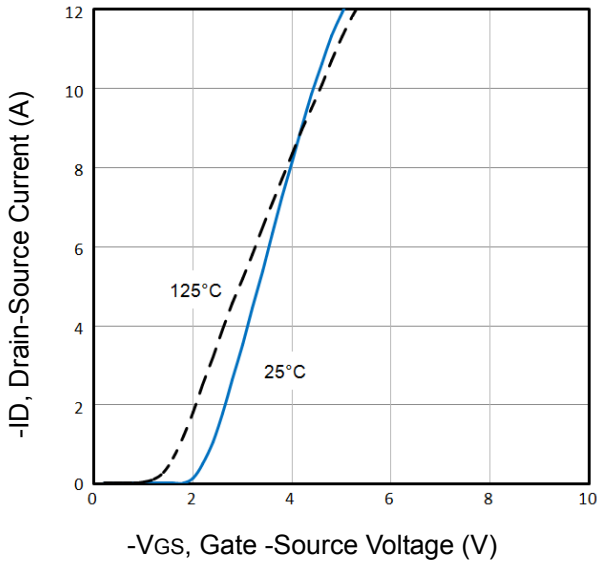

Fig3. Typical Transfer Characteristics

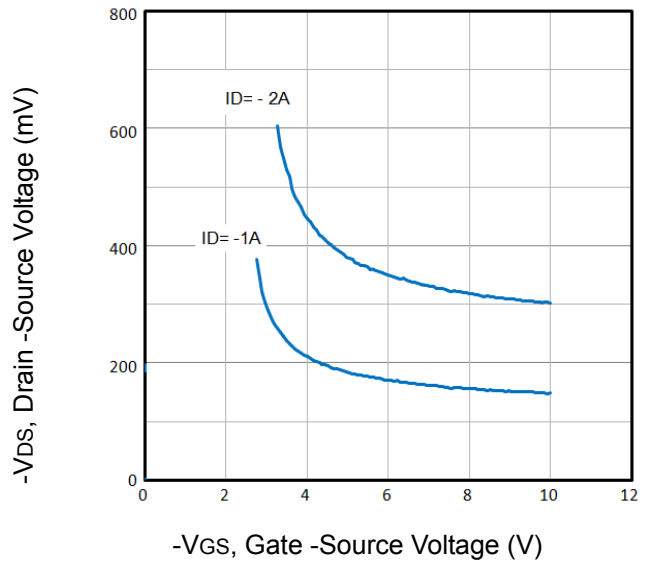

Fig4. Drain-Source Voltage vs Gate-Source Voltage

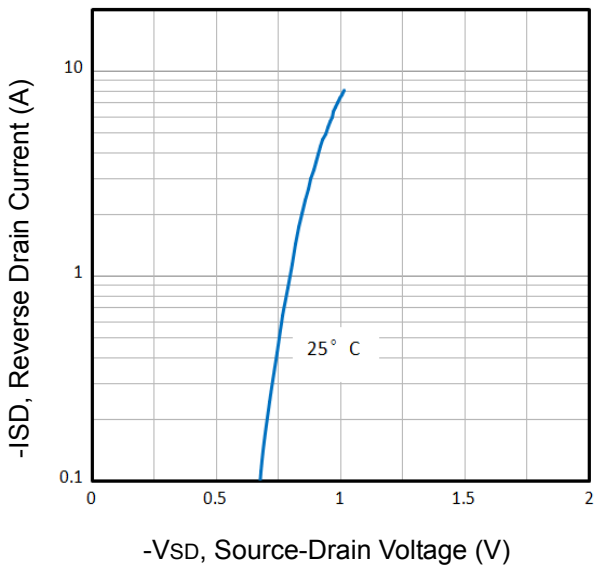

Fig5. Typical Source-Drain Diode Forward Voltage

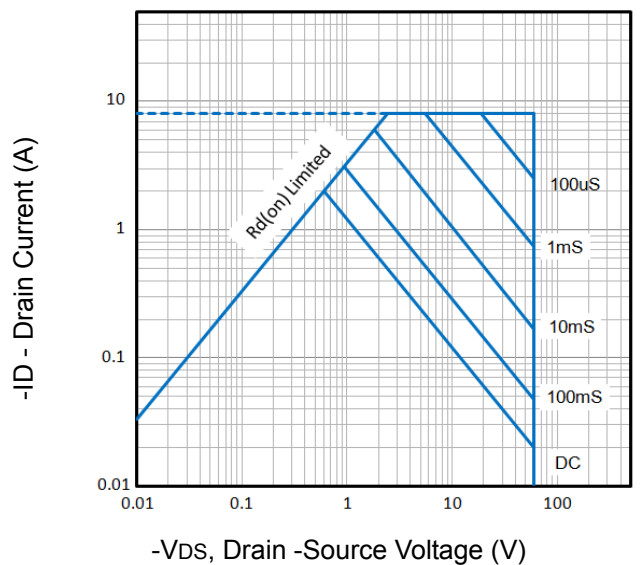

Fig6. Maximum Safe Operating Area

Typical Characteristics

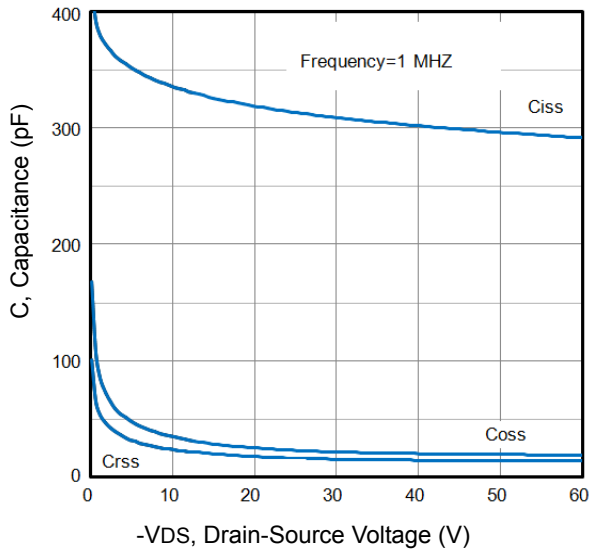

Fig7. Typical Capacitance Vs. Drain-Source Voltage

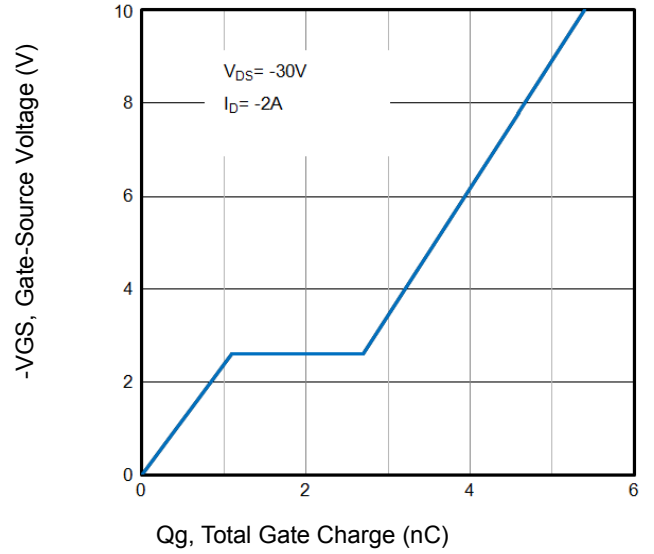

Fig8. Typical Gate Charge Vs. Gate-Source Voltage

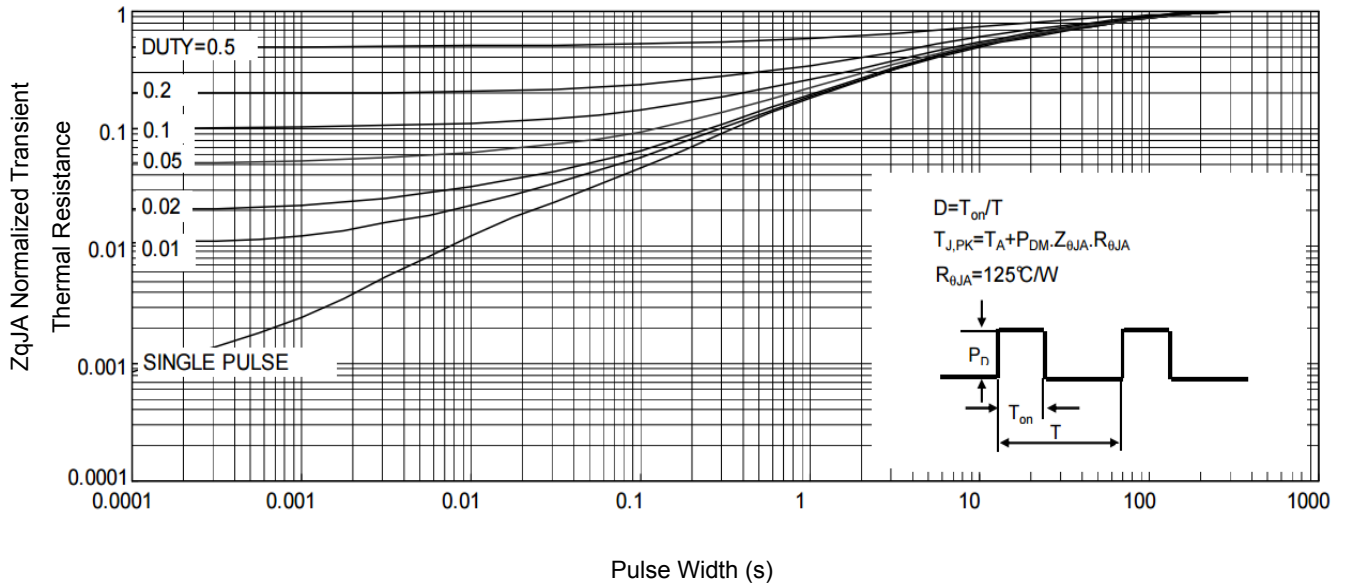

Fig9. Normalized Maximum Transient Thermal Impedance

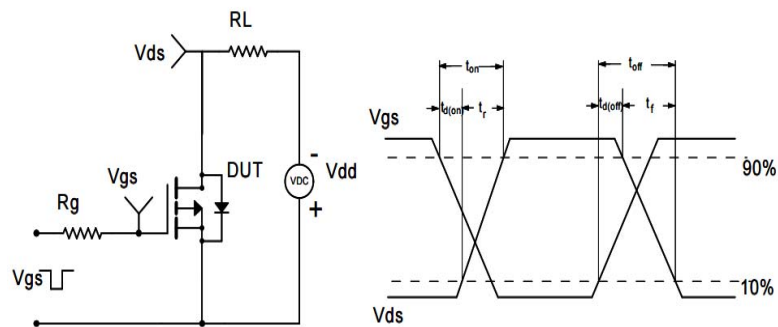

Fig10. Switching Time Test Circuit and waveforms

Package Mechanical Data:SOT-23

6 \ P E R O	' L P H Q V L R Q V L Q 0 L O O L P H W H U V	
	0 , 1	0 \$ ;
\$		
\$		
\$		
E		
F		
,		
(		
(		
H		7 < 3
H		
/		5 ( )
/		
	<i>f</i>	<i>f</i>