

Electrical Characteristics (T_J=25 °C, unless otherwise noted)

| Symbol | Parameter | Conditions | Min. | Typ. | Max. | Unit |
|---------------------|--|--|------|------|------|------|
| BV _{DSS} | Drain-Source Breakdown Voltage | V _{GS} =0V, I _D =250uA | 40 | --- | --- | V |
| R _{DS(ON)} | Static Drain-Source On-Resistance ² | V _{GS} =10V, I _D =12A | --- | 6.9 | 8.5 | mΩ |
| | | V _{GS} =4.5V, I _D =10A | --- | 8.8 | 12 | |
| V _{GS(th)} | Gate Threshold Voltage | V _{GS} =V _{DS} , I _D =250uA | 1.35 | 1.7 | 3 | V |
| I _{DSS} | Drain-Source Leakage Current | V _{DS} =32V, V _{GS} =0V, T _J =25°C | --- | --- | 1 | uA |
| | | V _{DS} =32V, V _{GS} =0V, T _J =55°C | --- | --- | 5 | |
| I _{GSS} | Gate-Source Leakage Current | V _{GS} =±20V, V _{DS} =0V | --- | --- | ±100 | nA |
| R _g | Gate Resistance | V _{DS} =0V, V _{GS} =0V, f=1MHz | --- | 1.7 | --- | Ω |
| Q _g | Total Gate Charge (4.5V) | V _{DS} =20V, V _{GS} =4.5V, I _D =12A | --- | 5.8 | --- | nC |
| Q _{gs} | Gate-Source Charge | | --- | 3 | --- | |
| Q _{gd} | Gate-Drain Charge | | --- | 1.2 | --- | |
| T _{d(on)} | Turn-On Delay Time | V _{DD} =15V, V _{GS} =10V, R _G =3.3Ω I _D =1A | --- | 14.3 | --- | ns |
| T _r | Rise Time | | --- | 5.6 | --- | |
| T _{d(off)} | Turn-Off Delay Time | | --- | 20 | --- | |
| T _f | Fall Time | | --- | 11 | --- | |
| C _{iss} | Input Capacitance | V _{DS} =15V, V _{GS} =0V, f=1MHz | --- | 690 | --- | pF |
| C _{oss} | Output Capacitance | | --- | 193 | --- | |
| C _{rss} | Reverse Transfer Capacitance | | --- | 38 | --- | |

Diode Characteristics

| Symbol | Parameter | Conditions | Min. | Typ. | Max. | Unit |
|-----------------|--|---|------|------|------|------|
| I _S | Continuous Source Current ^{1,5} | V _G =V _D =0V, Force Current | --- | --- | 60 | A |
| V _{SD} | Diode Forward Voltage ² | V _{GS} =0V, I _S =1A, T _J =25°C | --- | --- | 1 | V |

Note :

- 1.The data tested by surface mounted on a 1 inch² FR-4 board with 2OZ copper.
- 2.The data tested by pulsed , pulse width ≤ 300us , duty cycle ≤ 2%
- 3.The EAS data shows Max. rating . The test condition is V_{DD}=25V,V_{GS}=10V,L=0.1mH,I_{AS}=31A
- 4.The power dissipation is limited by 150°C junction temperature
- 5.The data is theoretically the same as I_D and I_{DM}, in real applications , should be limited by total power dissipation.



Typical Characteristics

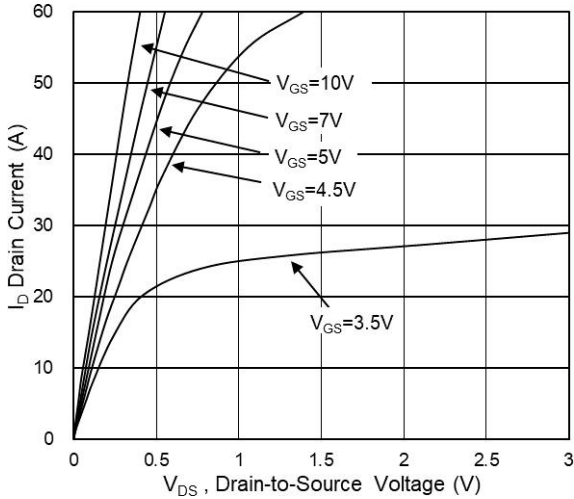

Fig.1 Typical Output Characteristics

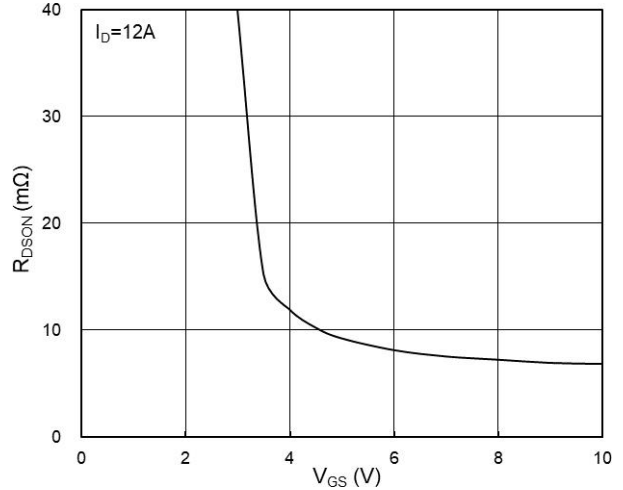

Fig.2 On-Resistance vs G-S Voltage

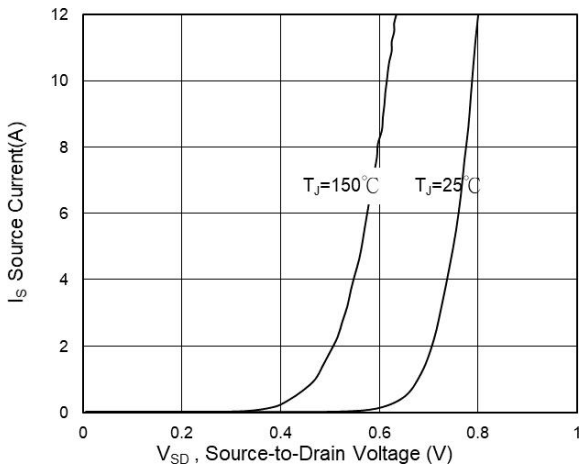

Fig.3 Source Drain Forward Characteristics

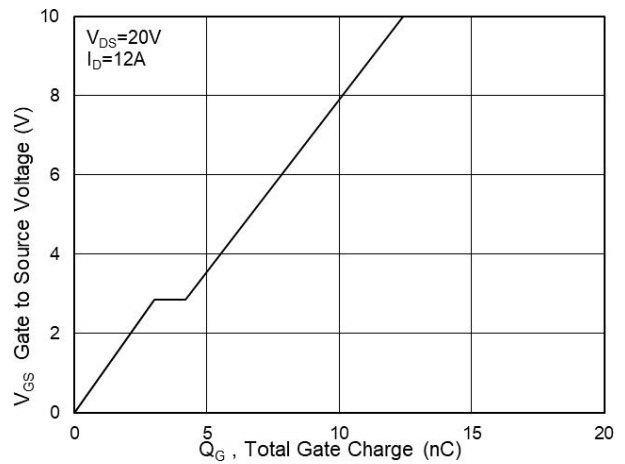

Fig.4 Gate-Charge Characteristics

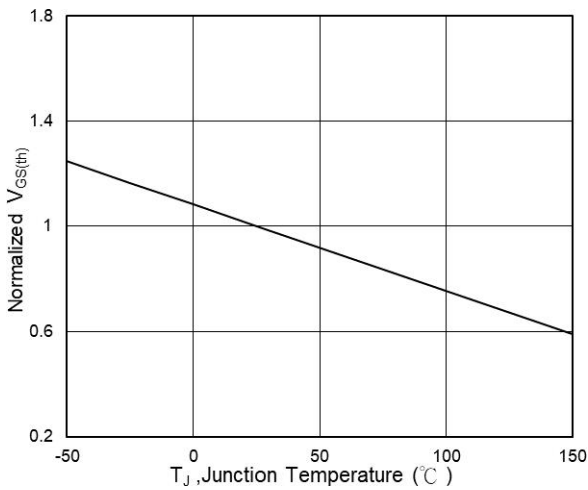

Fig.5 Normalized $V_{GS(th)}$ vs T_J

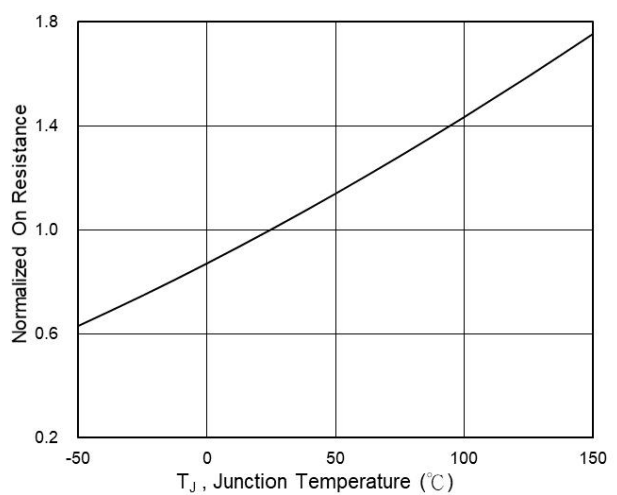

Fig.6 Normalized $R_{DS(on)}$ vs T_J

TMG60N04DF

Channel Enhancement Mosfet

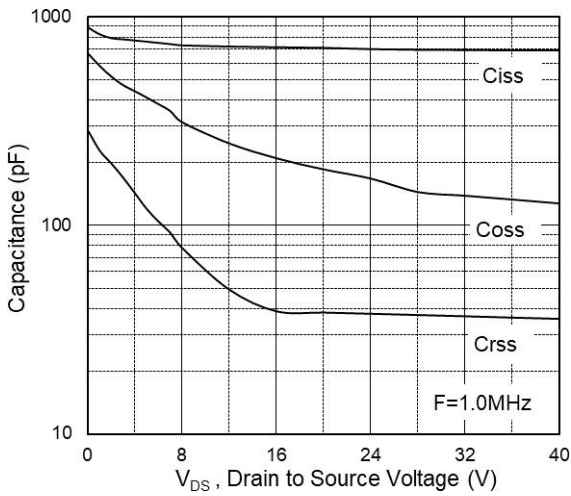

Fig.7 Capacitance

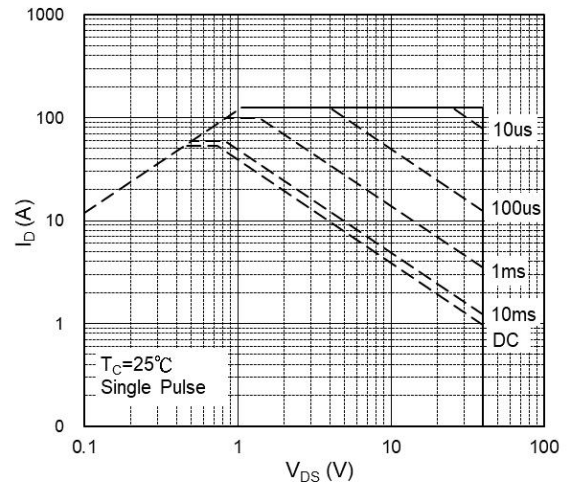

Fig.8 Safe Operating Area

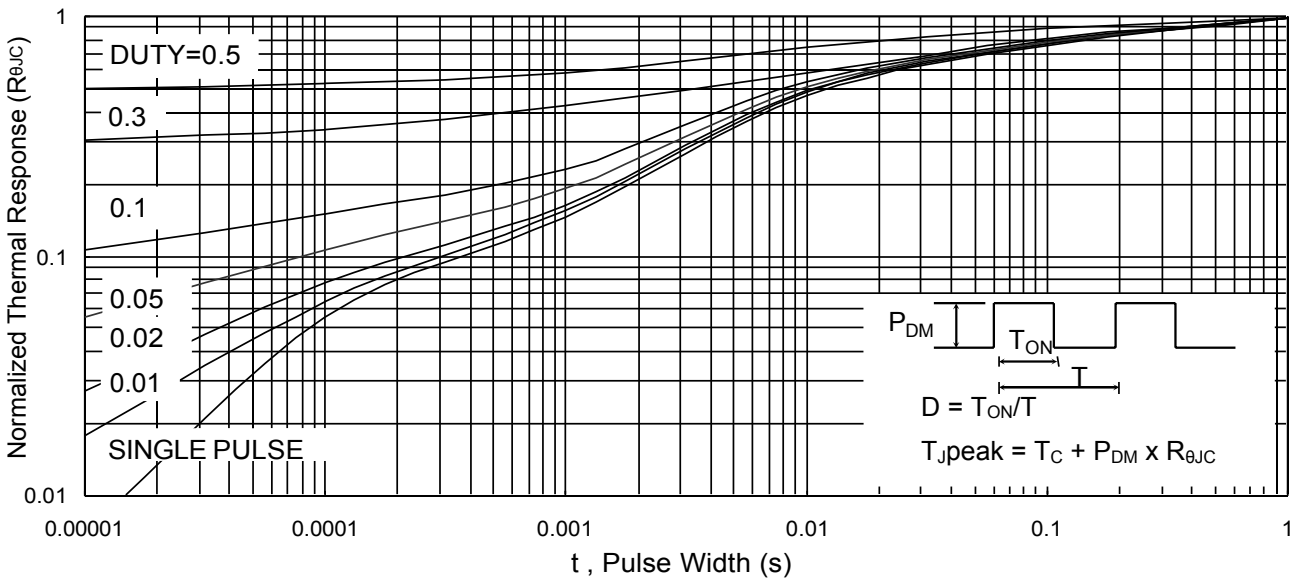

Fig.9 Normalized Maximum Transient Thermal Impedance

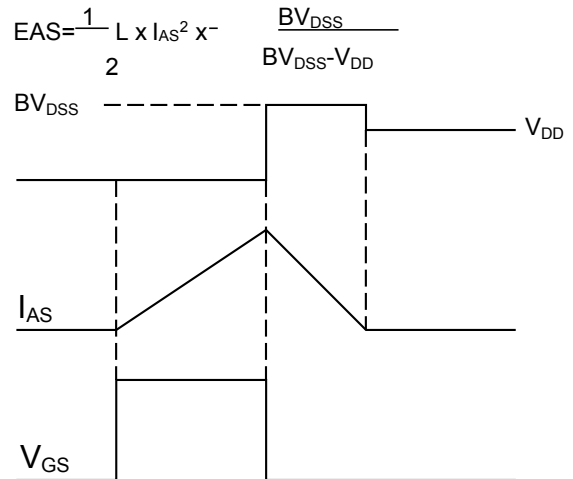
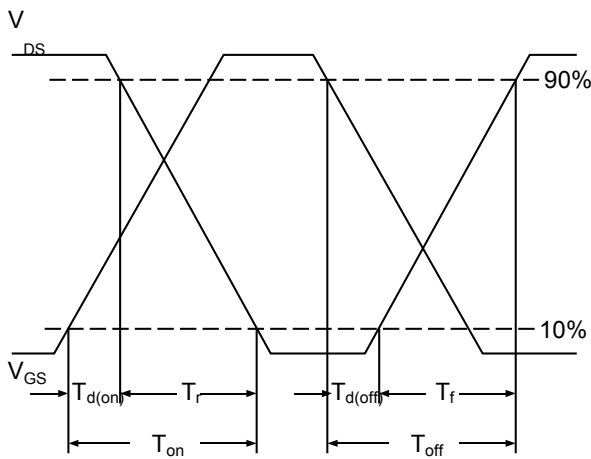
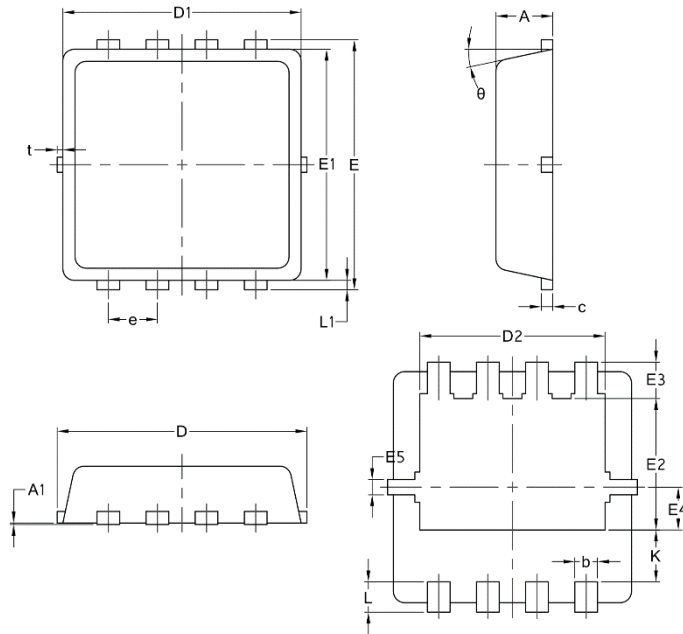

Fig.11 Unclamped Inductive Waveform

Package Mechanical Data:DFN3x3–8L



| Symbol | Common | | |
|--------|--------|-------|------|
| | mm | | |
| | Mim | Nom | Max |
| A | 0.70 | 0.75 | 0.85 |
| A1 | / | / | 0.05 |
| b | 0.20 | 0.30 | 0.40 |
| c | 0.10 | 0.152 | 0.25 |
| D | 3.15 | 3.30 | 3.45 |
| D1 | 3.00 | 3.15 | 3.25 |
| D2 | 2.29 | 2.45 | 2.65 |
| E | 3.15 | 3.30 | 3.45 |
| E1 | 2.90 | 3.05 | 3.20 |
| E2 | 1.54 | 1.74 | 1.94 |
| E3 | 0.28 | 0.48 | 0.65 |
| E4 | 0.37 | 0.57 | 0.77 |
| E5 | 0.10 | 0.20 | 0.30 |
| e | 0.60 | 0.65 | 0.70 |
| K | 0.59 | 0.69 | 0.89 |
| L | 0.30 | 0.40 | 0.50 |
| L1 | 0.06 | 0.125 | 0.20 |
| t | 0 | 0.075 | 0.13 |
| Φ | 10 | 12 | 14 |