





TM100N04D

N-Channel Enhancement Mosfet

Electrical Characteristics (T<sub>J</sub> = 25°C unless otherwise specified)

Symbol	Parameter	Conditions	Min.	Typ.	Max.	Unit
<b>Off Characteristics</b>						
V(BR) <sub>DS</sub>	Drain-Source Breakdown Voltage	I <sub>D</sub> = 250μA, V <sub>GS</sub> = 0V	40	-	-	V
I <sub>DS</sub>	Zero Gate Voltage Drain Current	V <sub>DS</sub> = 40V, V <sub>GS</sub> = 0V	-	-	1.0	μA
I <sub>GS</sub>	Gate-Body Leakage Current	V <sub>DS</sub> = 0V, V <sub>GS</sub> = ±20V	-	-	±100	nA
<b>On Characteristics</b>						
V <sub>GS(t)</sub>	Gate Threshold Voltage	V <sub>DS</sub> = V <sub>GS</sub> , I <sub>D</sub> = 250μA	1.3	1.9	2.5	V
R <sub>DS(ON)</sub>	Static Drain-Source ON-Resistance <sup>(4)</sup>	V <sub>GS</sub> = 10V, I <sub>D</sub> = 30A	-	3.8	5.1	mΩ
		V <sub>GS</sub> = 4.5V, I <sub>D</sub> = 20A	-	5.2	6.9	mΩ
<b>Dynamic Characteristics</b>						
C <sub>is</sub>	Input Capacitance	V <sub>GS</sub> = 0V, V <sub>DS</sub> = 20V, f = 1MHz	-	3278	-	pF
C <sub>os</sub>	Output Capacitance		-	267	-	pF
C <sub>rs</sub>	Reverse Transfer Capacitance		-	224	-	pF
Q <sub>g</sub>	Total Gate Charge	V <sub>GS</sub> = 0 to 10V V <sub>DS</sub> = 20V, I <sub>D</sub> = 30A	-	73	-	nC
Q <sub>g</sub>	Gate Source Charge		-	15	-	nC
Q <sub>g</sub>	Gate Drain("Miller") Charge		-	16	-	nC
<b>Switching Characteristics</b>						
t <sub>d(on)</sub>	Turn-On Delay Time	V <sub>GS</sub> = 10V, V <sub>DD</sub> = 20V I <sub>D</sub> = 30A, R <sub>GEN</sub> = 3Ω	-	12	-	ns
t <sub>r</sub>	Turn-On Rise Time		-	29	-	ns
t <sub>d(off)</sub>	Turn-Off Delay Time		-	60	-	ns
t <sub>f</sub>	Turn-Off Fall Time		-	16	-	ns
<b>Drain-Source Diode Characteristics and Max Ratings</b>						
I <sub>S</sub>	Maximum Continuous Drain to Source Diode Forward Current		-	-	100	A
I <sub>SM</sub>	Maximum Pulsed Drain to Source Diode Forward Current		-	-	320	A
V <sub>SM</sub>	Drain to Source Diode Forward Voltage	V <sub>GS</sub> = 0V, I <sub>S</sub> = 30A	-	-	1.2	V
t <sub>rr</sub>	Body Diode Reverse Recovery Time	I <sub>F</sub> = 20A, di/dt = 100A/us	-	16	-	ns
Q <sub>rr</sub>	Body Diode Reverse Recovery Charge		-	10	-	nC

- Note
1. Repetitive Rating: Pulse Width Limited by Maximum Junction Temperature.
  2. EAS condition: Starting T<sub>J</sub>=25C, V<sub>DD</sub>=20V, V<sub>G</sub>=10V, R<sub>G</sub>=25ohm, L=0.5mH, I<sub>AS</sub>=25A
  3. R<sub>θJA</sub> is measured with the device mounted on a 1inch<sup>2</sup> pad of 2oz copper FR4 PCB
  4. Pulse Test: Pulse Width ≤ 300μs, Duty Cycle ≤ 0.5%.



## Typical Performance

Figure 1: Output Characteristics

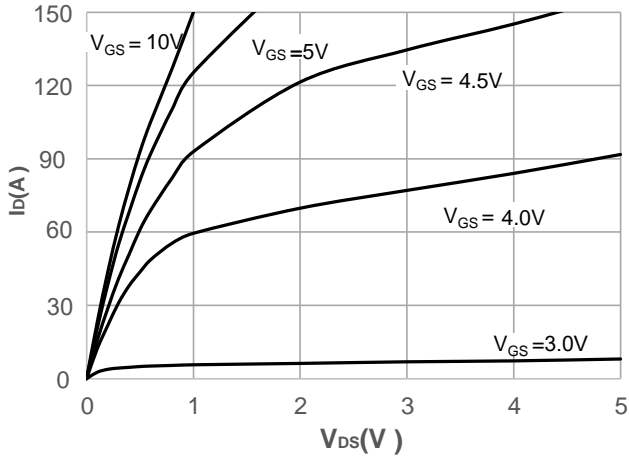


Figure 2: Typical Transfer Characteristics

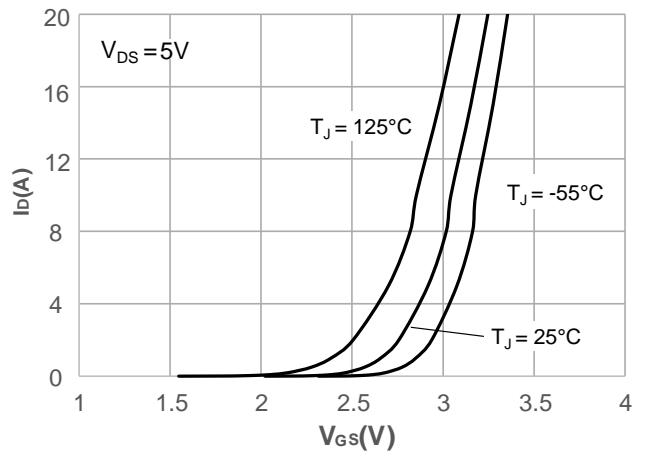


Figure 3: On-resistance vs. Drain Current

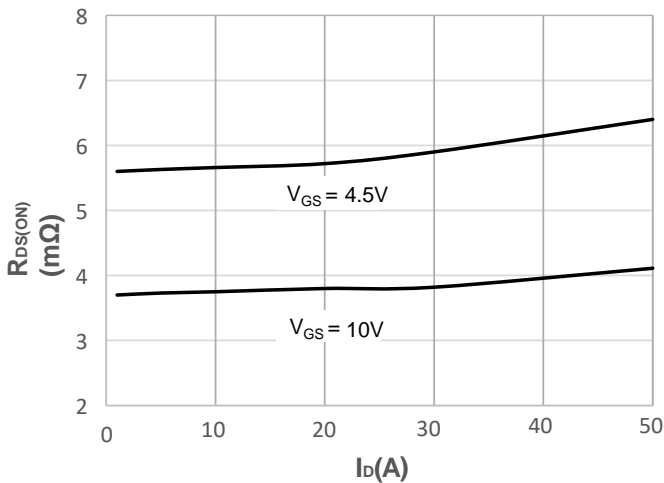


Figure 4: Body Diode Characteristics

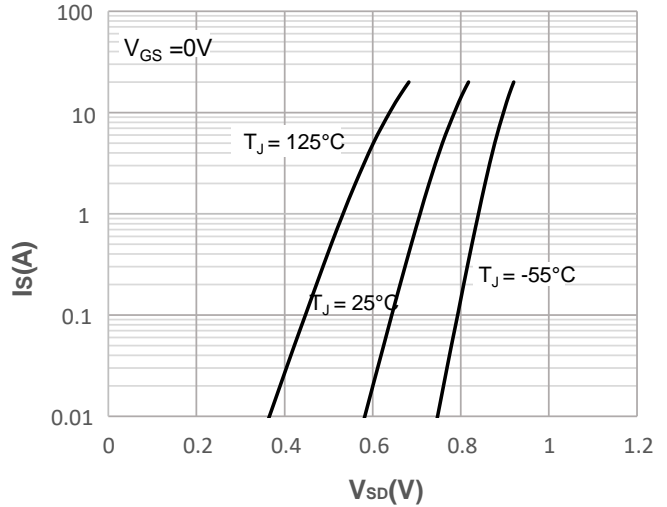


Figure 5: Gate Charge Characteristics

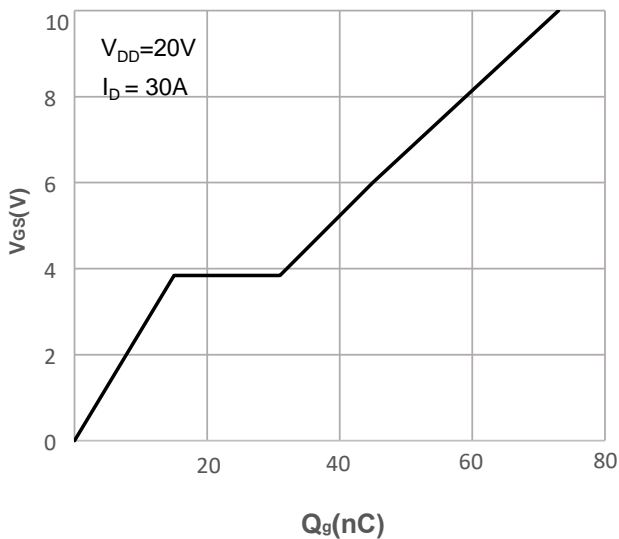
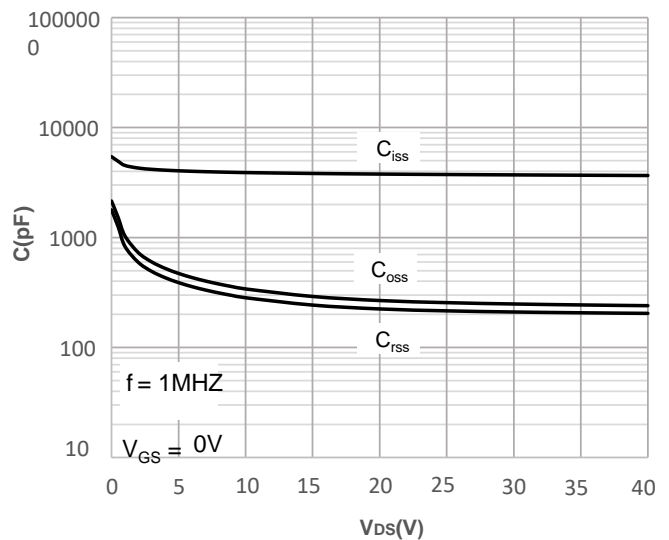


Figure 6: Capacitance Characteristics





TM100N04D

N-Channel Enhancement Mosfet

Figure 7: Normalized Breakdown voltage vs. Junction Temperature

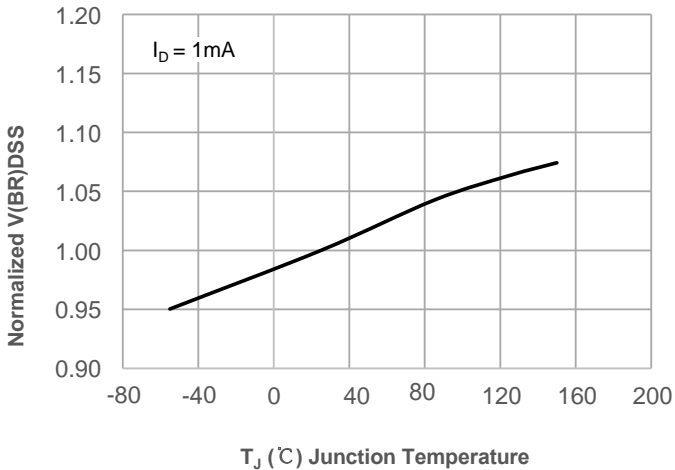


Figure 8: Normalized on Resistance vs. Junction Temperature

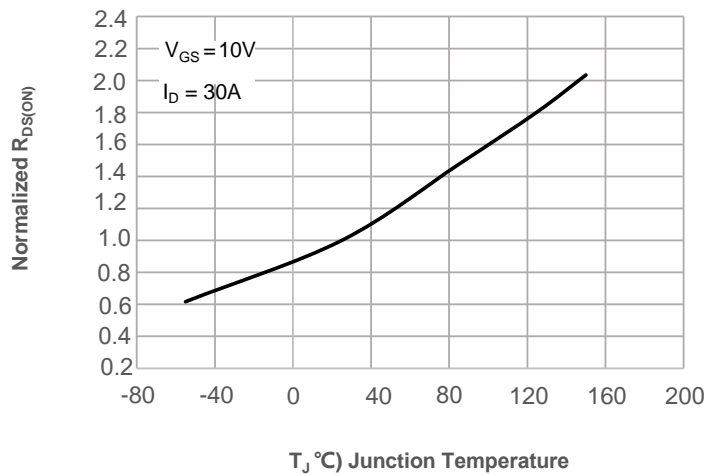


Figure 9: Maximum Safe Operating Area

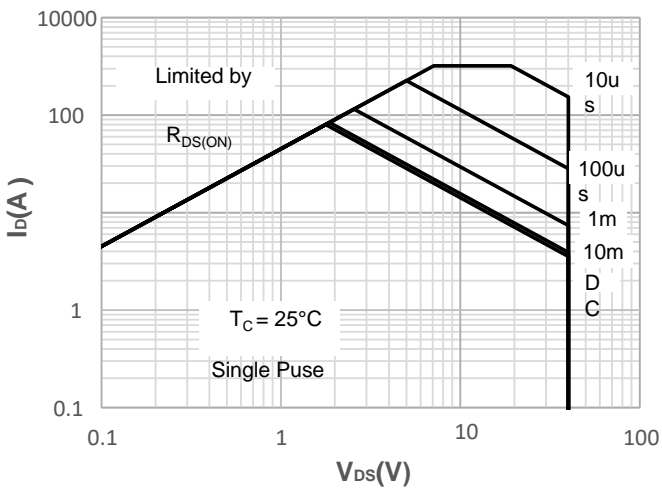


Figure 10: Maximum Continuous Driant Current vs. Case Temperature

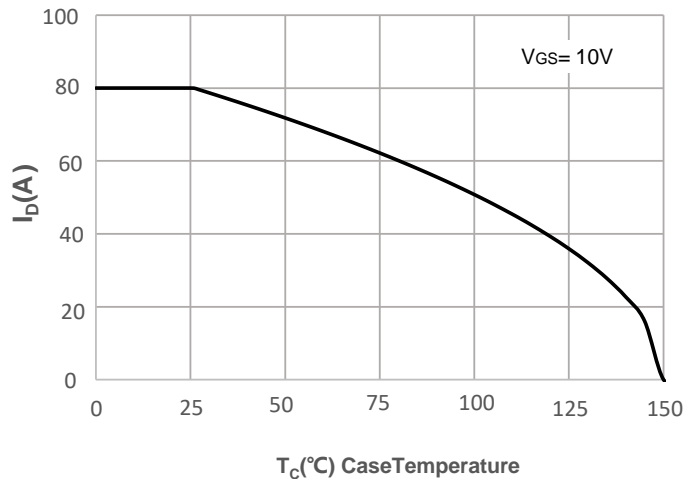


Figure 11: Normalized Maximum Transient Thermal Impedance

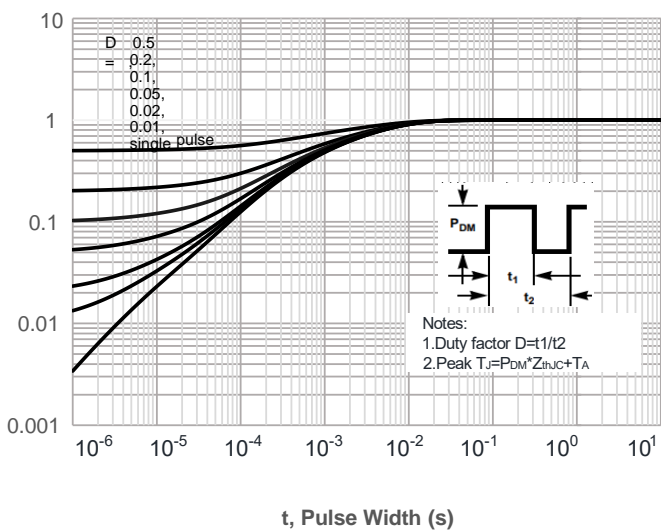
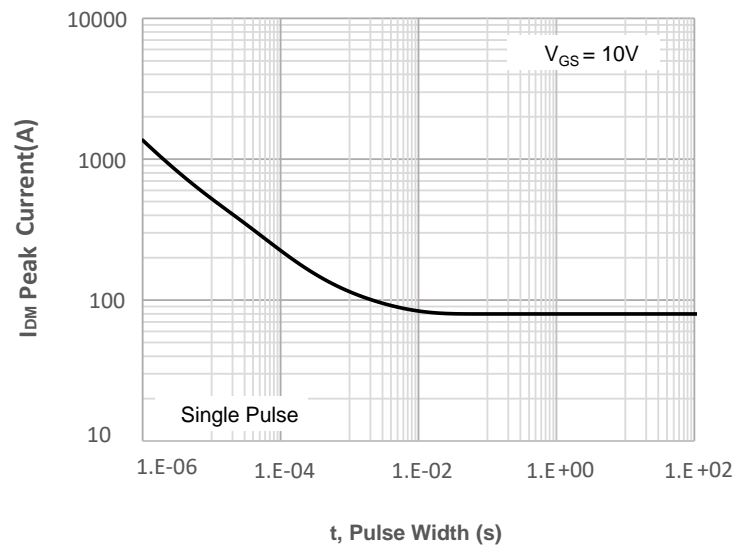
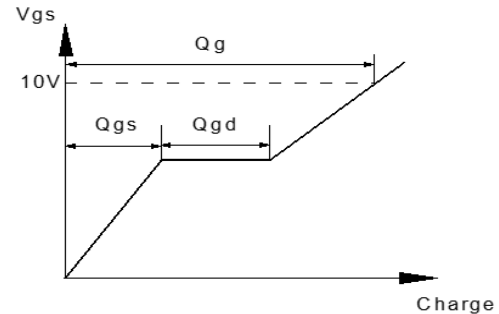
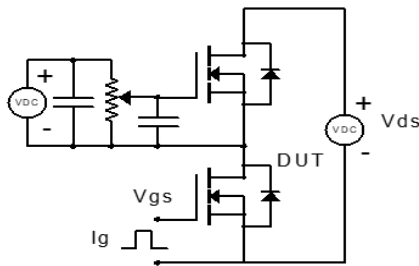


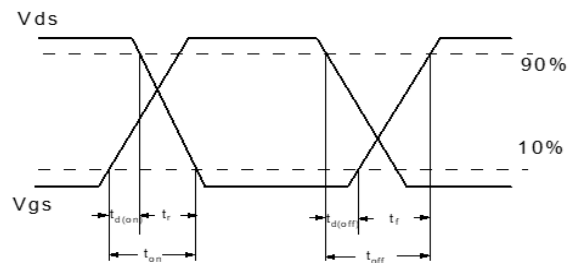
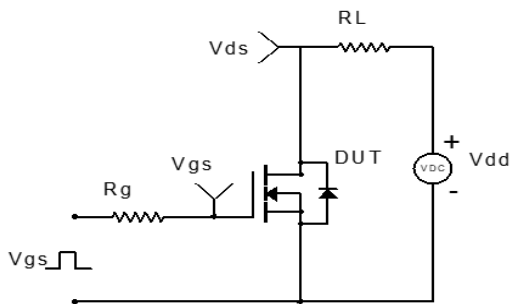
Figure 12: Peak Current Capacity



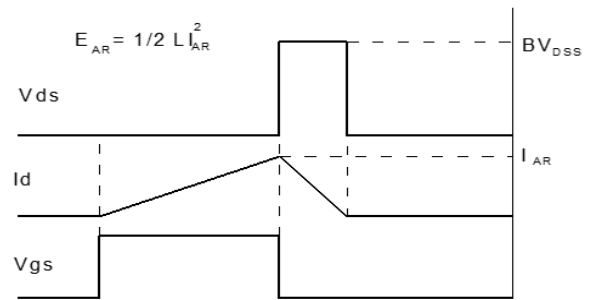
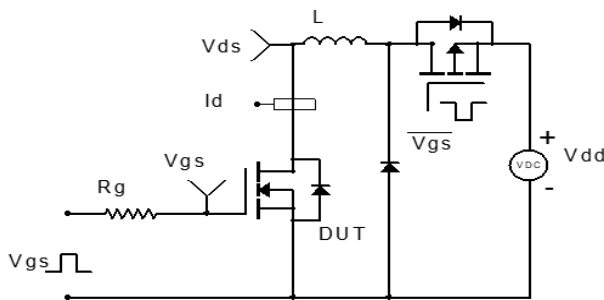
## Test Circuit



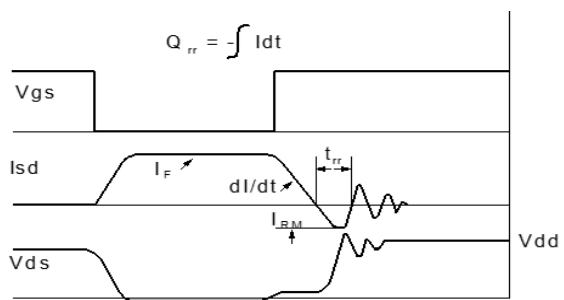
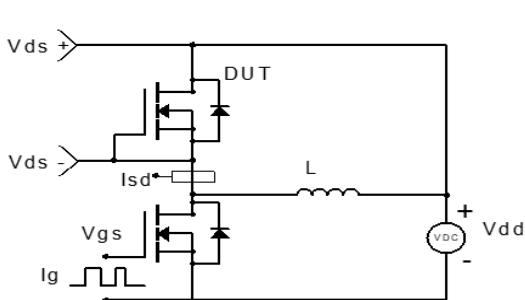
**Figure 1: Gate Charge Test Circuit & Waveform**



**Figure 2: Resistive Switching Test Circuit & Waveform**

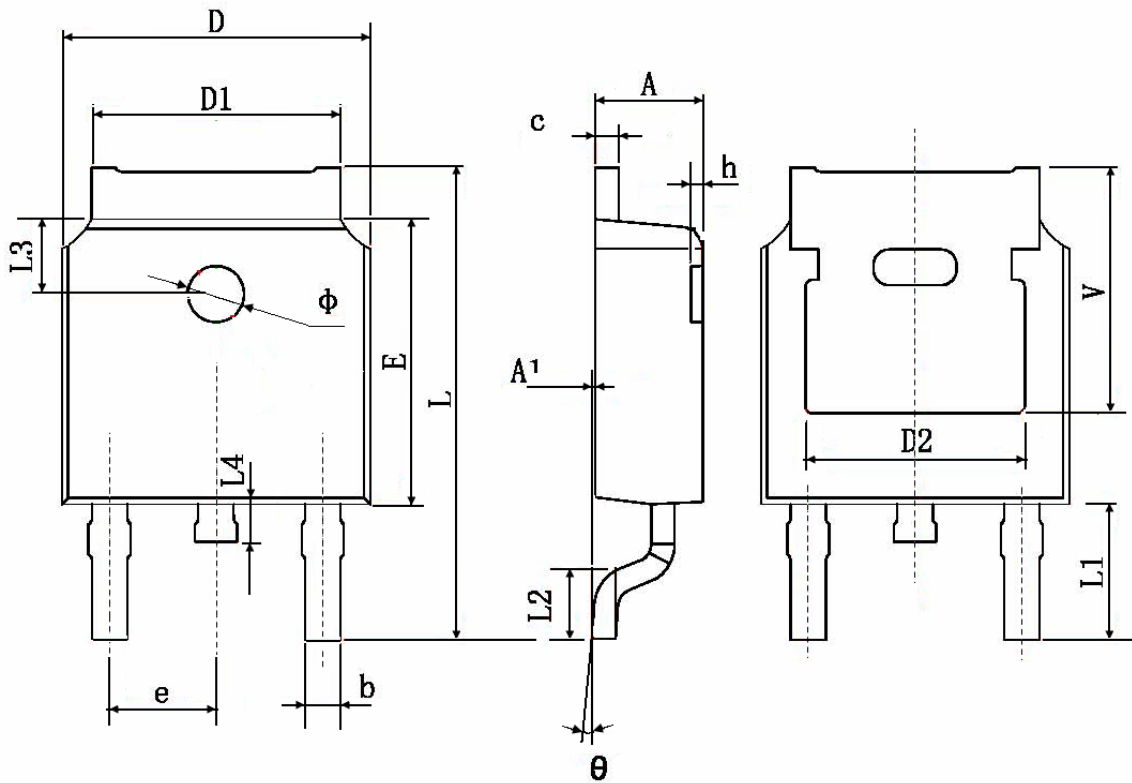


**Figure 3: Unclamped Inductive Switching Test Circuit & Waveform**



**Figure 4: Diode Recovery Test Circuit & Waveform**

## Package Information: TO-252-3L



Symbol	Dimensions In Millimeters		Dimensions In Inches	
	Min.	Max.	Min.	Max.
A	2.200	2.400	0.087	0.094
A1	0.000	0.127	0.000	0.005
b	0.660	0.860	0.026	0.034
c	0.460	0.580	0.018	0.023
D	6.500	6.700	0.256	0.264
D1	5.100	5.460	0.201	0.215
D2	4.830 TYP.		0.190 TYP.	
E	6.000	6.200	0.236	0.244
e	2.186	2.386	0.086	0.094
L	9.800	10.400	0.386	0.409
L1	2.900 TYP.		0.114 TYP.	
L2	1.400	1.700	0.055	0.067
L3	1.600 TYP.		0.063 TYP.	
L4	0.600	1.000	0.024	0.039
φ	1.100	1.300	0.043	0.051
θ	0°	8°	0°	8°
h	0.000	0.300	0.000	0.012
V	5.350 TYP.		0.211 TYP.	