

Electrical Characteristics (T_J = 25°C, unless otherwise noted)

Parameter	Symbol	Test Conditions	Min.	Typ.	Max.	Unit
Static Characteristics						
Drain-Source Breakdown Voltage	V_{(BR)DSS}	V _{GS} = 0V, I _D = 250μA	150	-	-	V
Gate-body Leakage current	I_{gss}	V _{DS} = 0V, V _{GS} = ±20V	-	-	±100	nA
Zero Gate Voltage Drain Current	T _J =25°C	V _{DS} = 150V, V _{GS} = 0V	-	-	1	μA
	T _J =100°C		-	-	100	
Gate-Threshold Voltage	V_{GS(th)}	V _{DS} = V _{GS} , I _D = 250μA	0.5	1.5	2.5	V
Drain-Source on-Resistance ⁴	R_{DS(on)}	V _{GS} = 10V, I _D = 4A	-	180	220	mΩ
Forward Transconductance ⁴	g_{fs}	V _{DS} = 10V, I _D = 4A	-	25	-	S
Dynamic Characteristics⁵						
Input Capacitance	C_{iss}	V _{DS} = 75V, V _{GS} = 0V, f = 1MHz	-	450	-	pF
Output Capacitance	C_{oss}		-	23	-	
Reverse Transfer Capacitance	C_{rss}		-	14	-	
Gate Resistance	R_g	f = 1MHz	-	1.5	-	Ω
Switching Characteristics⁵						
Total Gate Charge	Q_g	V _{GS} = 10V, V _{DS} = 75V, I _D = 1.5A	-	8.2	-	nC
Gate-Source Charge	Q_{gs}		-	1.5	-	
Gate-Drain Charge	Q_{gd}		-	2.2	-	
Turn-on Delay Time	t_{d(on)}	V _{GS} = 10V, V _{DD} = 75V, R _G = 6Ω, I _D = 1A, R _G = 75Ω	-	8.2	-	ns
Rise Time	t_r		-	10.2	-	
Turn-off Delay Time	t_{d(off)}		-	20.5	-	
Fall Time	t_f		-	15.3	-	
Drain-Source Body Diode Characteristics						
Diode Forward Voltage ⁴	V_{SD}	I _S = 1A, V _{GS} = 0V	-	-	1.2	V
Continuous Source Current	T _C =25°C	I_S	-	-	4.0	A

Notes:

1. Repetitive rating, pulse width limited by junction temperature T_{J(MAX)}=150°C.
2. The EAS data shows Max. rating . The test condition is V_{DD}=25V, V_{GS}=10V, L=0.1mH, I_{AS}=5A.
3. The data tested by surface mounted on a 1 inch² FR-4 board with 2OZ copper, The value in any given application depends on the user's specific board design.
4. The data tested by pulsed , pulse width ≤ 300us , duty cycle ≤ 2%.
5. This value is guaranteed by design hence it is not included in the production test.

Typical Characteristics

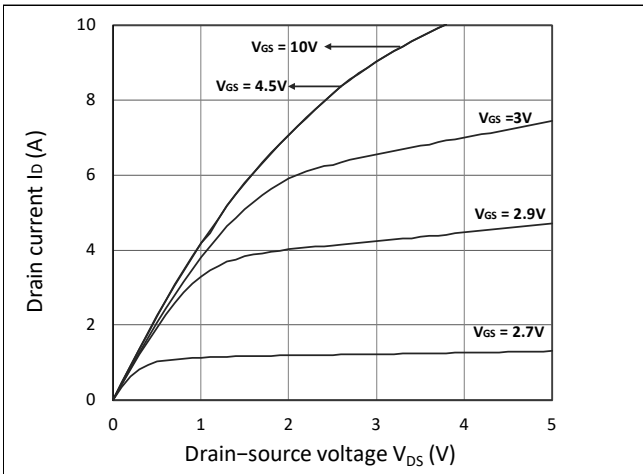

Figure 1. Output Characteristics

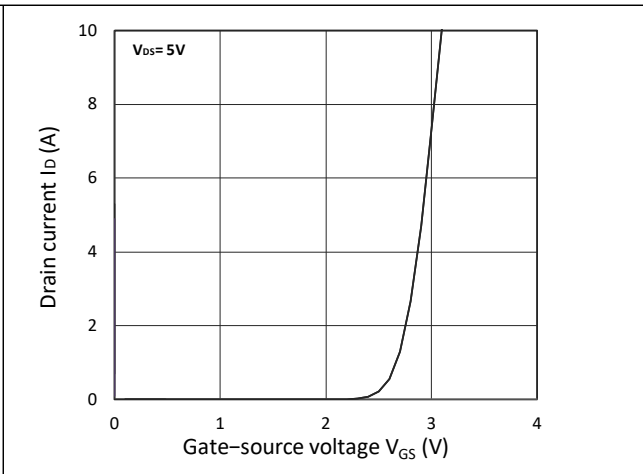

Figure 2. Transfer Characteristics

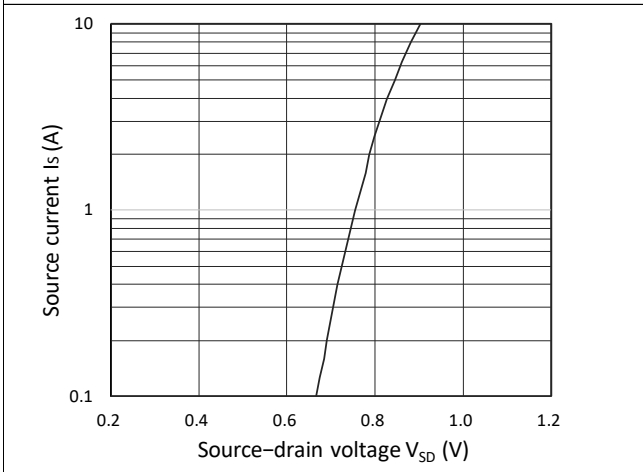

Figure 3. Forward Characteristics of Reverse

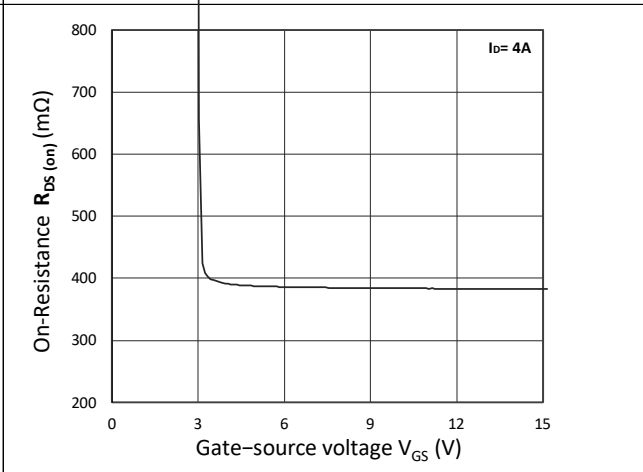

Figure 4. $R_{DS(ON)}$ vs. V_{GS}

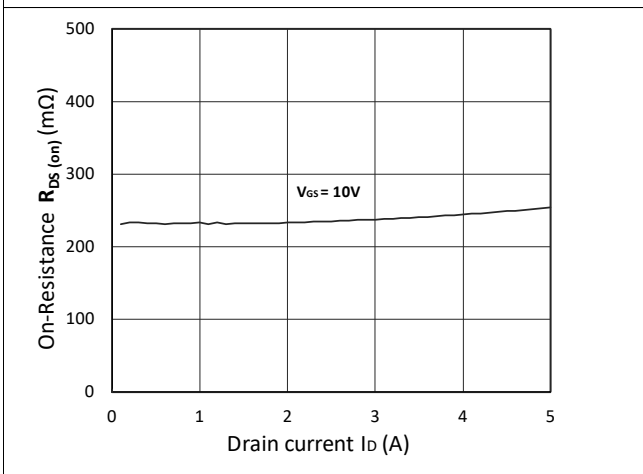

Figure 5. $R_{DS(ON)}$ vs. I_D

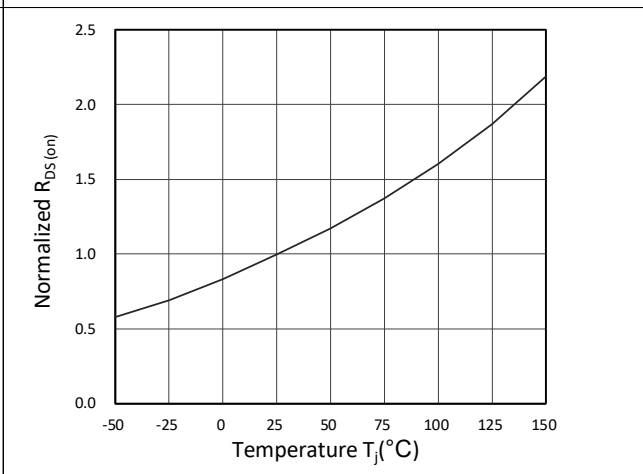

Figure 6. Normalized $R_{DS(ON)}$ vs. Temperature

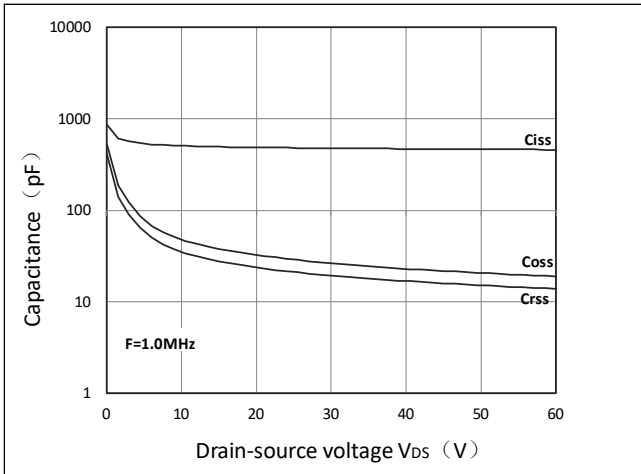

Figure 7. Capacitance Characteristics

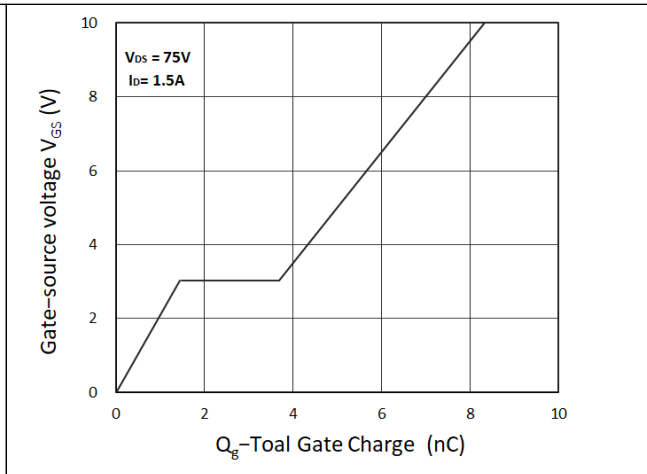

Figure 8. Gate Charge Characteristics

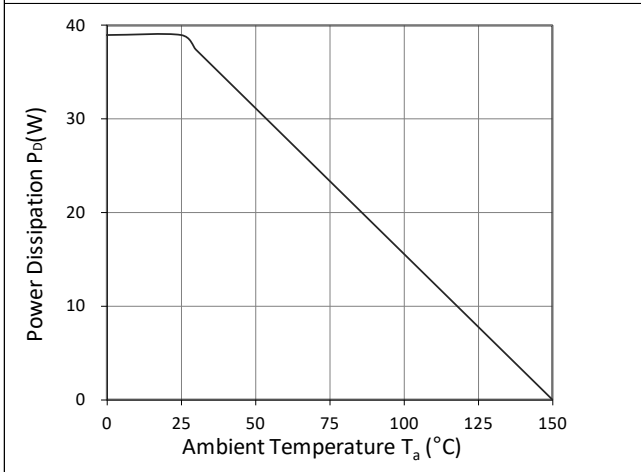

Figure 9. Power Dissipation

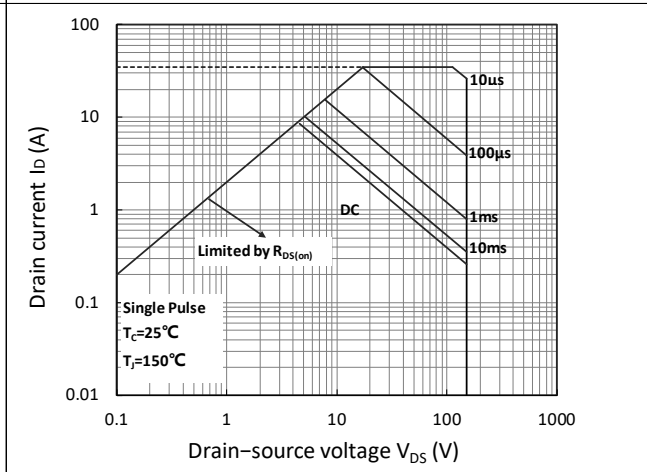

Figure 10. Safe Operating Area

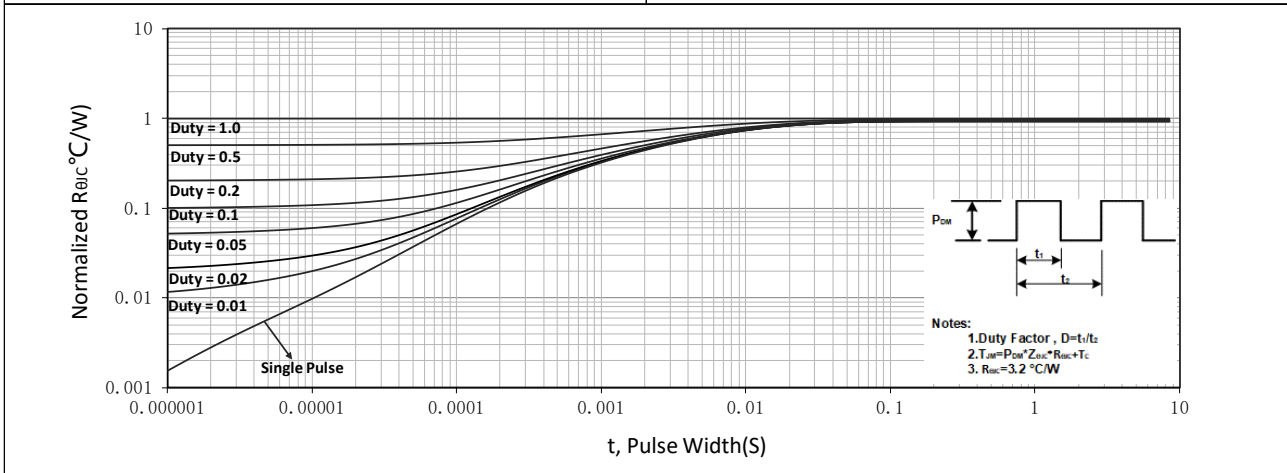

Figure 11. Normalized Maximum Transient Thermal Impedance

Test Circuit

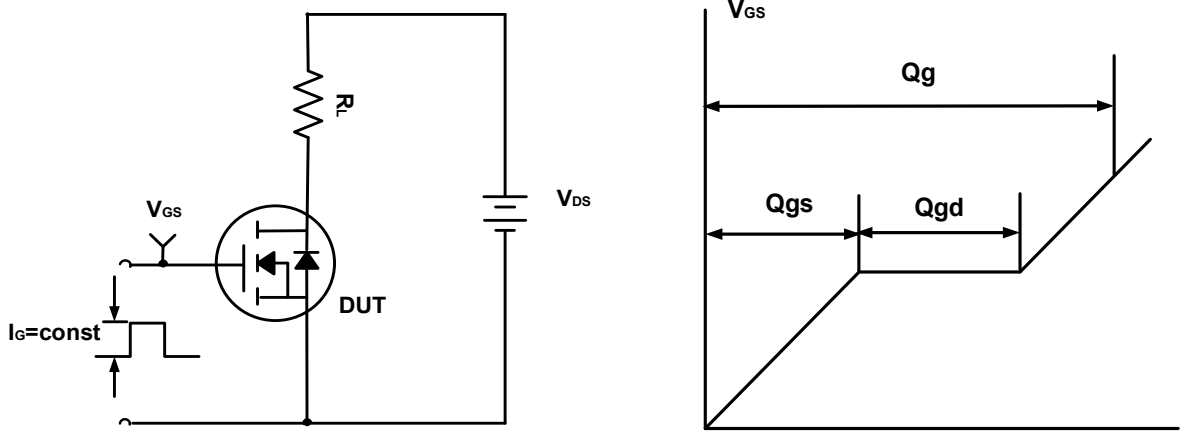

Figure A. Gate Charge Test Circuit & Waveforms

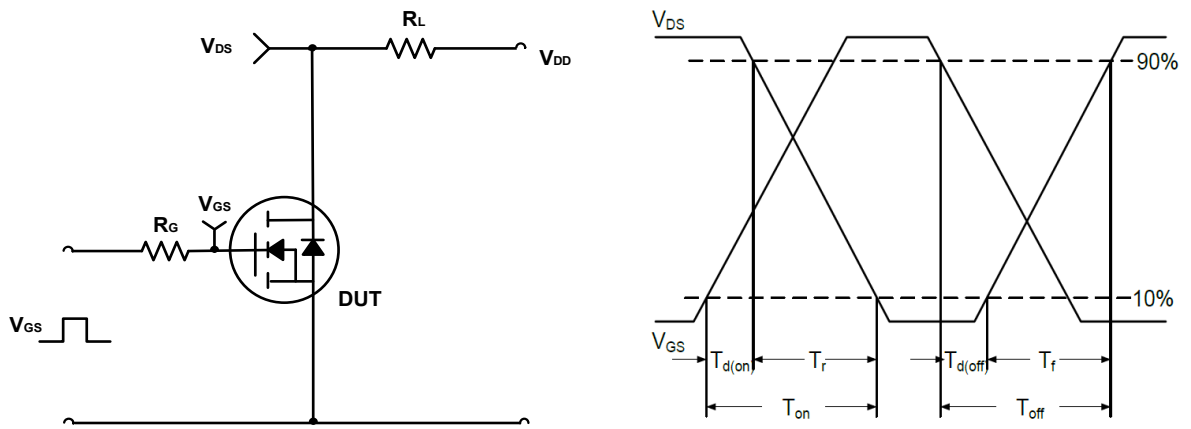

Figure B. Switching Test Circuit & Waveforms

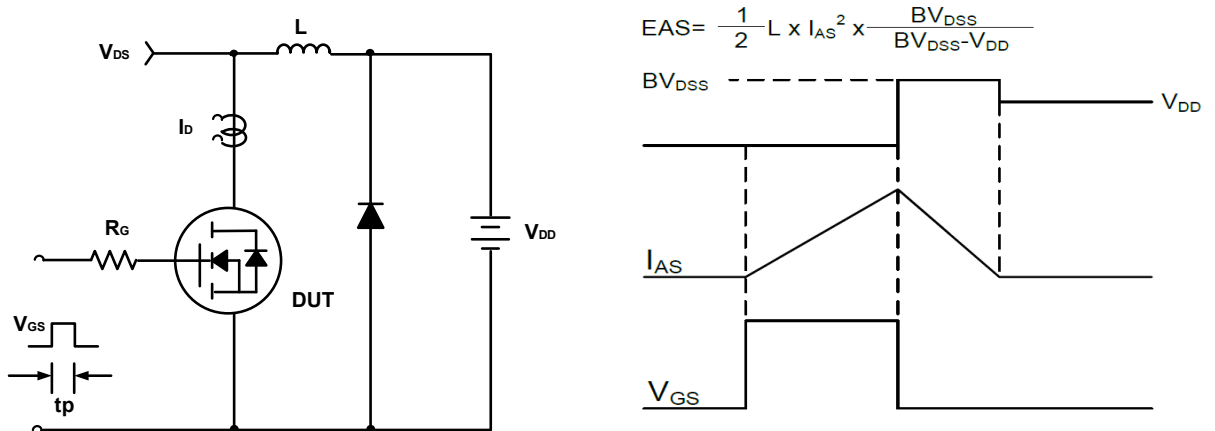
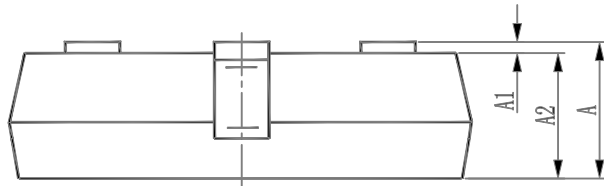

Figure C. Unclamped Inductive Switching Circuit & Waveforms

Package Mechanical Data: SOT-23-3L



6 \ PERO	'LPHQVLRQV ,Q 0LOOL	PHWHU V LPHQVLRQV ,Q ,QFKHV
	0LQ	0D[
\$		
\$		
\$		
E		
F		
'		
(
(
H	% 6 &	
H		
/		
	<i>f</i>	<i>f</i>