

NOTES:

1. CONTROLLING DIMENSIONS ARE IN MILLIMETERS (MM).
2. DIMENSION D1 & E1 DOES NOT INCLUDE MOLD PROTRUSION.
3. COPLANARITY OF ALL LEADS SHALL BE (BEFORE TEST) 0.089 MAX. FROM THE SEATING PLANE, UNLESS OTHERWISE SPECIFIED.
4. GENERAL PHYSICAL OUTLINE SPEC IS REFER TO TMC'S FINAL VISUAL INSPECTION SPEC UNLESS OTHERWISE SPECIFIED.

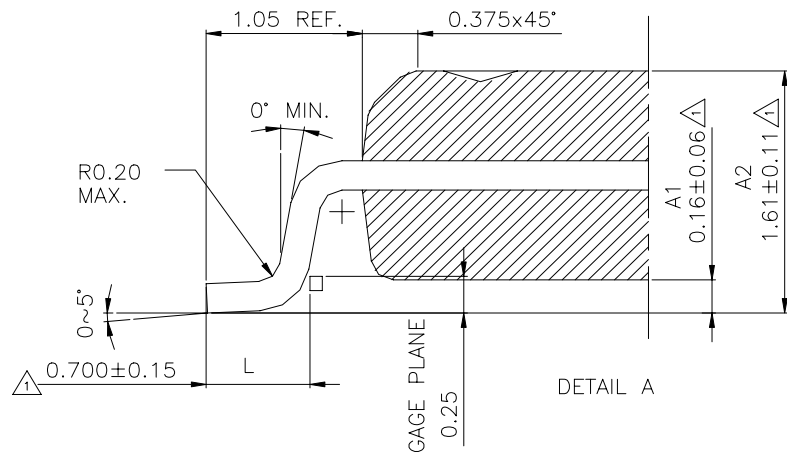

3			
2			
1	MODIFY DIMENSION.		劉昭真 06/11/'98
REV.	DESCRIPTION OF REVISION		SIGNATURE/ DATE
晶揚科技股份有限公司 Taiwan Micropaq Corporation		TITLE SOP 8 LD PACKAGE OUTLINE DWG.	
DWG. NO. EOL-S0080150-001 R1		FILE S8150001	
DESIGNER	DATE	MATERIAL	SCALE
劉昭真	06/11/'98	A194	6:1
CHECKER	DATE	PROCESSES	SHEET NO.
			1 OF 1
APPROVED	DATE	UNIT	
		MM	
		THIRD ANGLE PROJECTION .XXXX ±.0005 .XXX ±.0025 .XX ±.0100 .X ±.0250 ALL DIMENSIONS IN MILLIMETERS.	